

GT MOMENTUM™

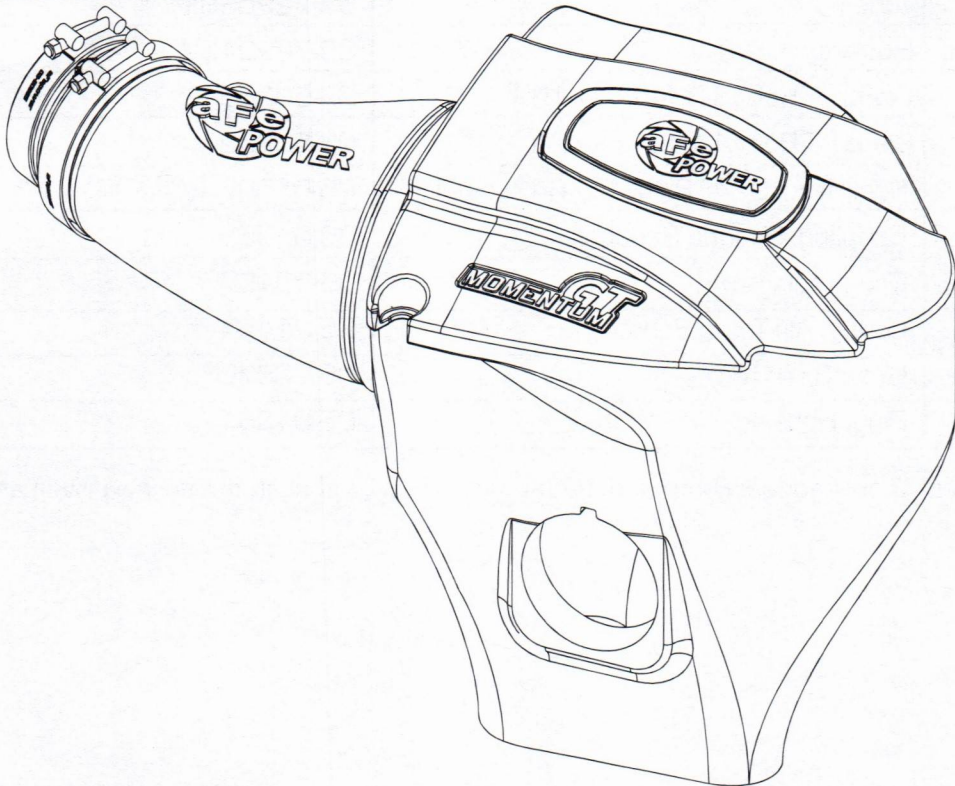

advanced FLOW engineering

Cold Air Intake System

Instruction Manual P/N: 51-72203 / 54-72203

Make: **Dodge** Model: **Challenger** Year: **2011-2023**

Engine: **V8-6.4L HEMI**

Make: **Dodge** Model: **Charger** Year: **2012-2023**

Engine: **V8-6.4L HEMI**

Make: **Chrysler** Model: **300** Year: **2012-2014**

Engine: **V8-6.4L HEMI**

Make: **Chrysler** Model: **300 C** Year: **2023-2023**

Engine: **V8-6.4L HEMI**

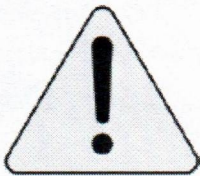

- Please read the entire instruction manual before proceeding.
- Ensure all components listed are present.
- If you are missing any of the components, call customer support at 951-493-7185.
- Ensure you have all necessary tools before proceeding.
- Do not attempt to work on your vehicle when the engine is hot.
- Disconnect the negative battery terminal before proceeding.
- Retain factory parts for future use.

Label	Qty.	Description	Part Number
A1	1	Air Filter (Pro DRY S)	21-91092 (Grey Media)
A2	1	Air Filter (Pro-5R)	24-91092 (Blue Meida)
B	1	Tube	05-72203B1
C	1	Housing	05-72201B2
D	1	Clamp, T-Bolt (3-3/4"-4-1/16")	03-50265
E	1	Clamp, T-Bolt (4-1/8"-4-1/2")	03-50262
F	1	Seal, Trim; 3/4" Bulb, 15/64" Edge (21")	05-01507
G	1	Coupling, Silicone Reducer	05-01555
H	1	Grommet	03-50167
I	1	Fitting, Air Temp Sensor	05-01454
J	1	Hose 3/4" (6.5")	05-00070
K	1	Plug, Housing	05-01361

Tools needed: Tools needed: 8mm and 10mm nut driver or socket, flat screw driver, and T20 torx driver.

Warranty Information available at: <https://afepower.com/contact#warranty>

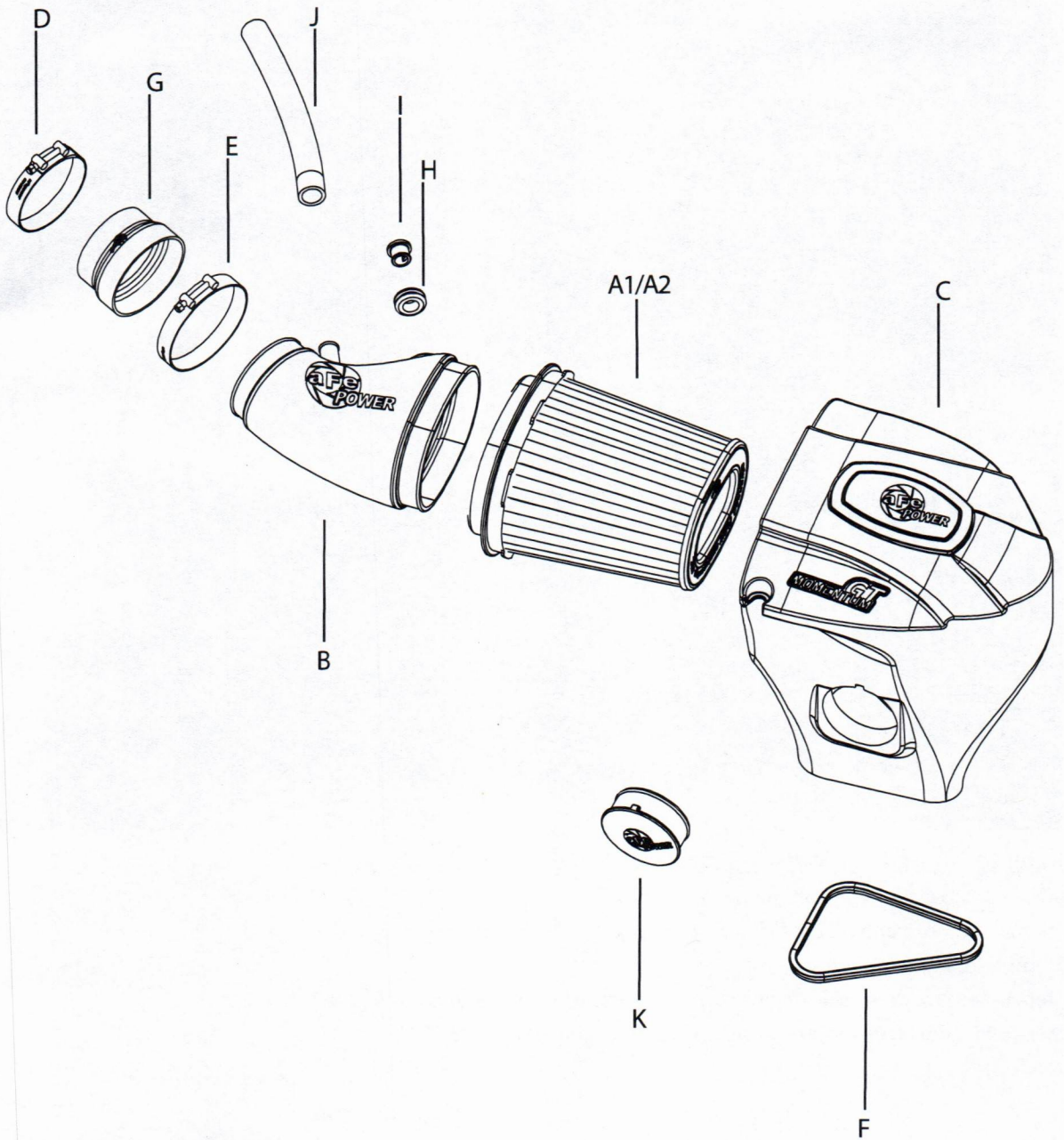

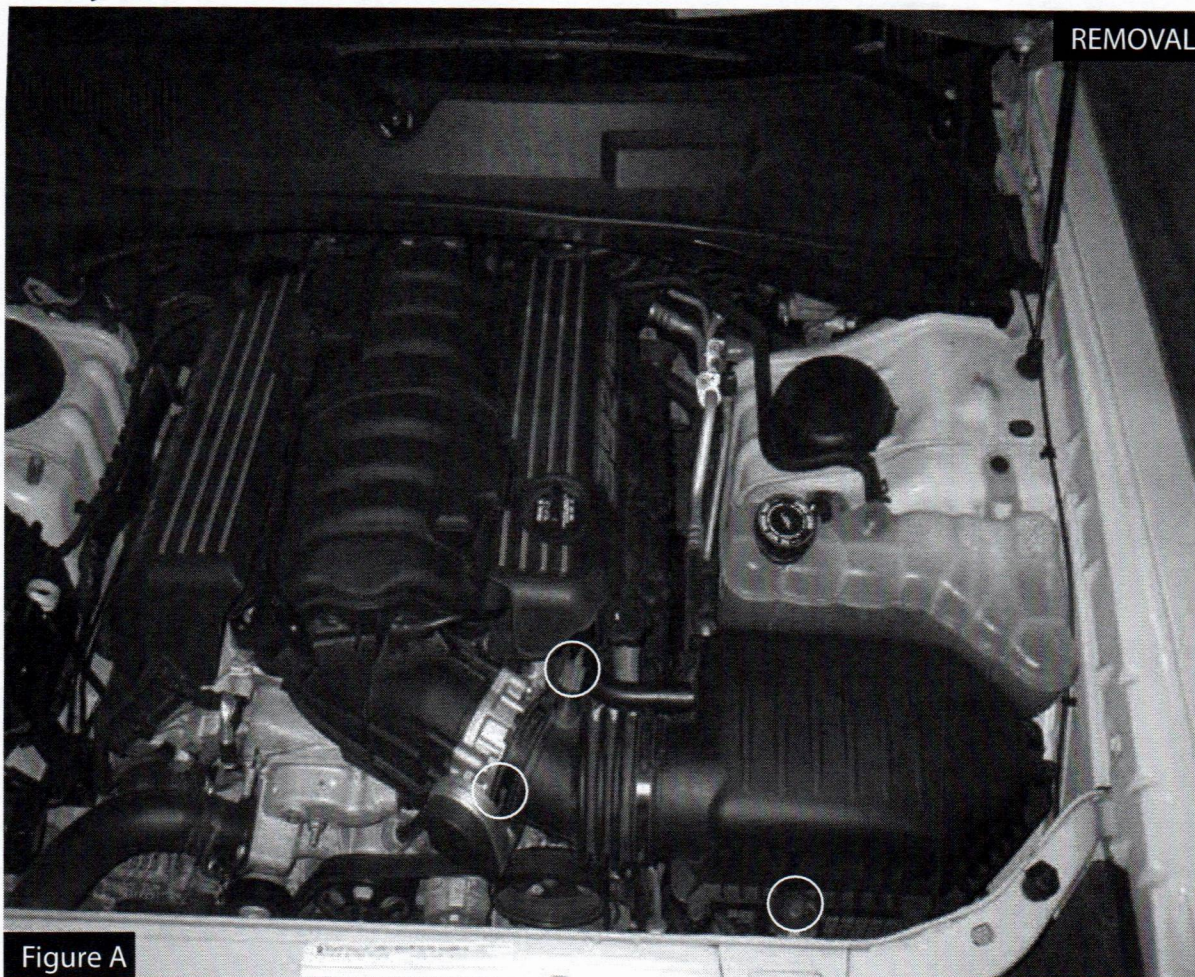

Figure A

Refer to Figure A for Steps 1-5

Step 1: Remove 8mm bolt off the factory air box.

Step 2: Loosen clamp off the factory intake tube.

Step 3: Unplug Temp sensor.

Step 4: Remove driver side engine valve cover off, and remove crank case hose off.

Step 5: Pull the factory intake air system out of engine bay.



Figure B

Refer to Figure B for Steps 6-8

Step 6: Transfer the grommet from the factory air box to the aFe housing.

Step 7: Install the trim seal on the bottom edge of the aFe housing.

Step 8: Slide the aFe filter inside the aFe housing until it locks in place. Install clamp on the filter end but do not tighten at this time



Figure C

Refer to Figure C for Step 9

Step 9: For the 2015 challenger, if you wish to use the headlight inlet duct, pop the cap off the center of the headlight and install on the aFe housing the aFe inlet duct (Sold Separately, P/N: 54-72203-S). For all other vehicle, leave the housing inlet open to get more air or close it off with the furnished plug to block off the hot engine air.

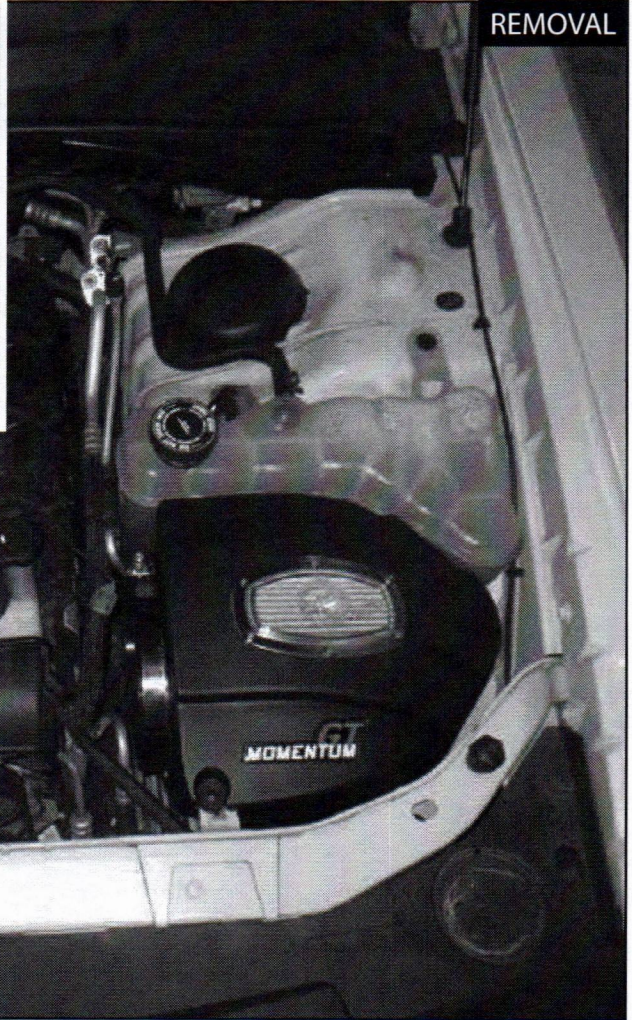
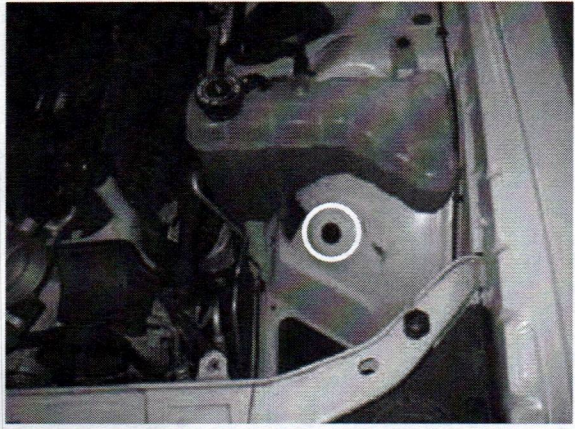

Figure D

Refer to Figure D for Steps 10-12

Step 10: Make sure factory grommet is installed correctly into hole.

Step 11: Install aFe housing assembly into vehicle.

Step 12: Install coupling with clamps over the throttle body. Do not tighten yet.



Figure E

Refer to Figure E for Steps 13-15

Step 13: Install grommet into hole in aFe tube then press the aluminum fitting in it.

Step 14: Remove the temperature sensor from the factory tube. Secure it into the aluminum fitting by turning clockwise.

Step 15: Install furnished hose onto aFe tube.

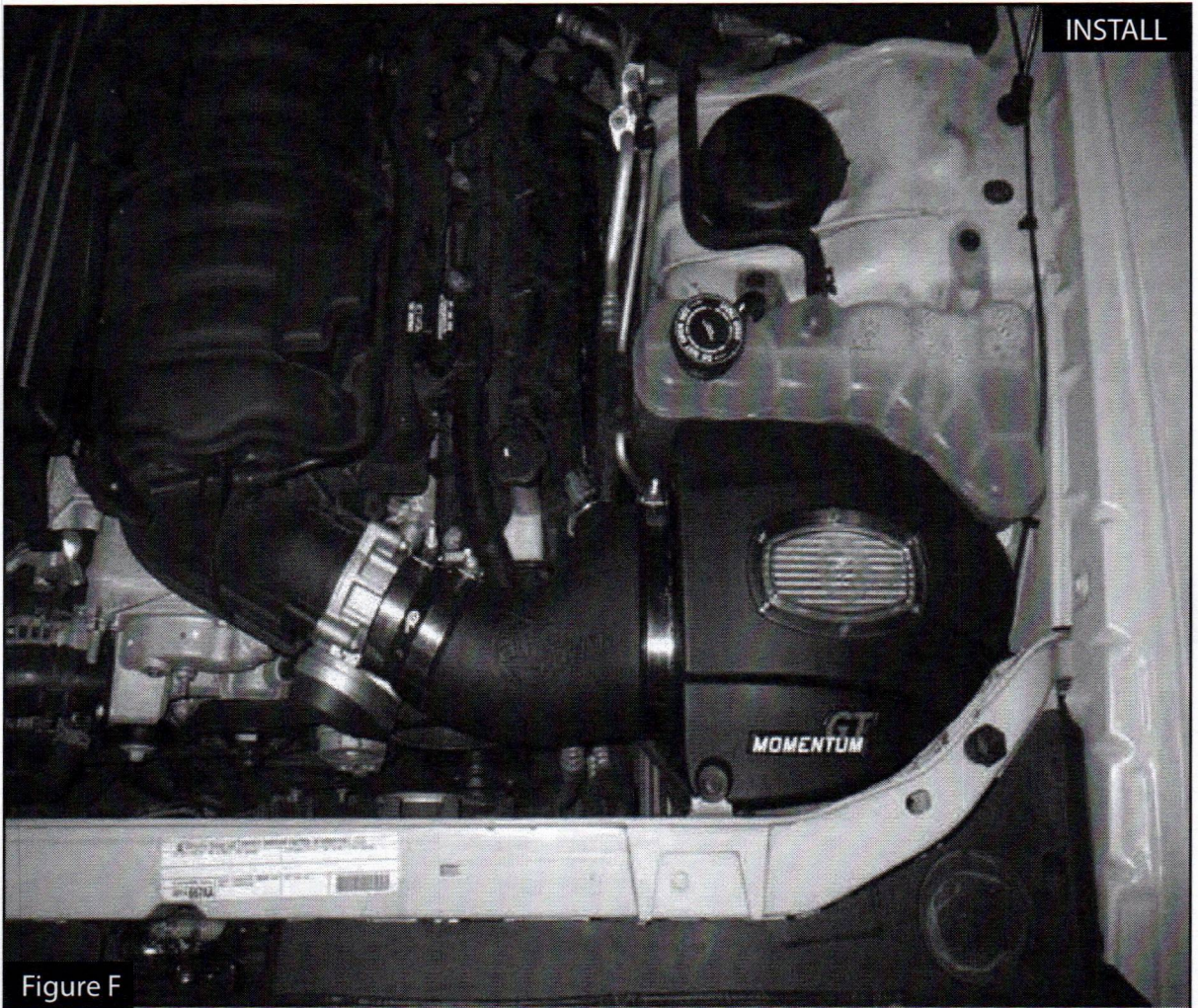

Figure F

Refer to Figure F for Steps 16-18

Step 16: install the tube into the vehicle by sliding it first into the filter then into the coupling.

Step 17: Connect the crank case hose to the valve.

Step 18: Align tube correctly, then tighten all clamps

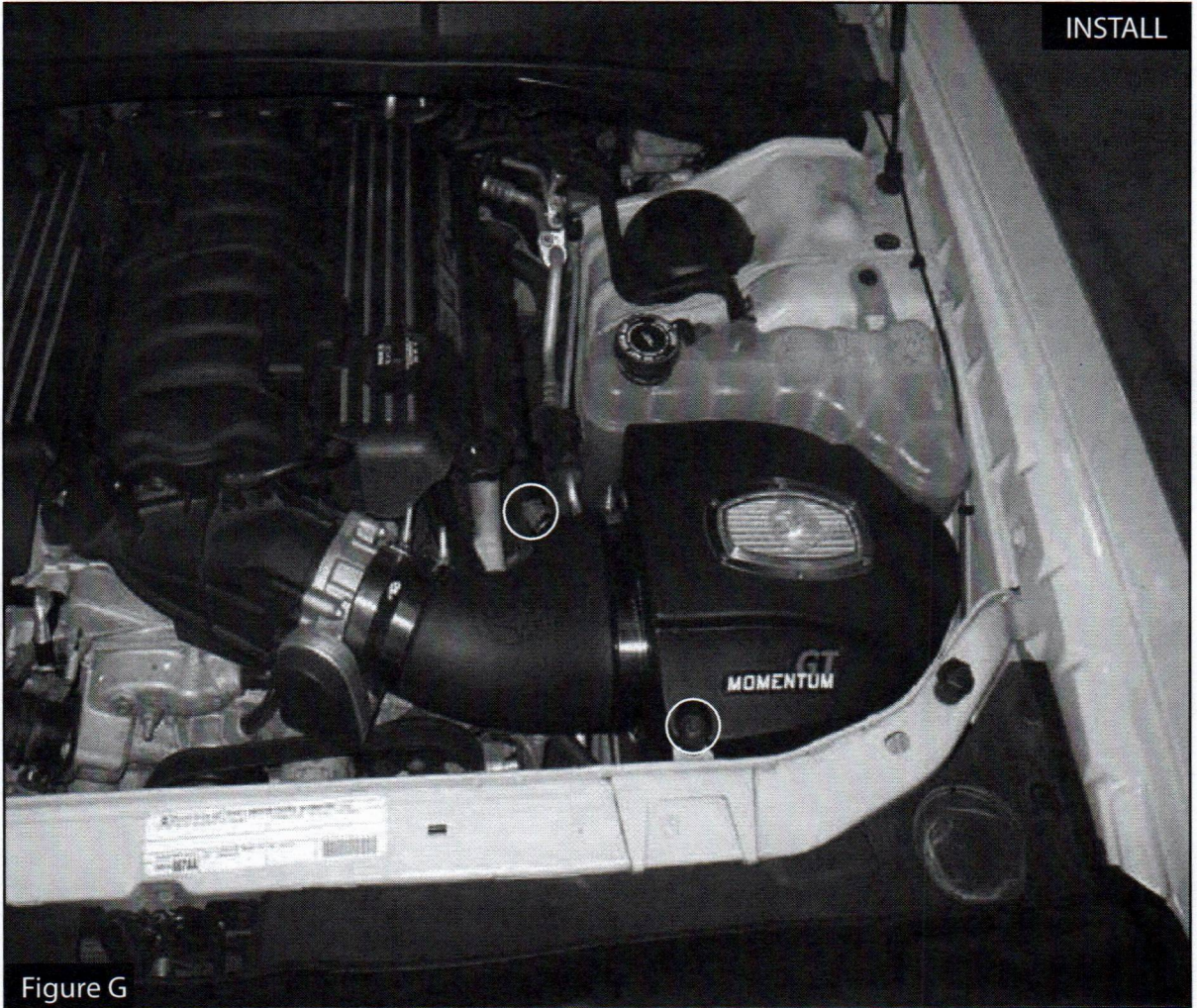

Figure G

Refer to Figure G for Steps 19-21

Step 19: Re-connect the temperature sensor.

Step 20: Re-install the factory bolt removed at step 1 to secure the housing.

Step 21: Re-install the valve cover.

NOTE: Place enclosed CARB EO sticker on a smooth/clean surface on or near the air intake system.

EO identification label is required to pass the smog check inspection.

Your installation is now completed. Thank you for choosing aFePower.

Page left blank intentionally

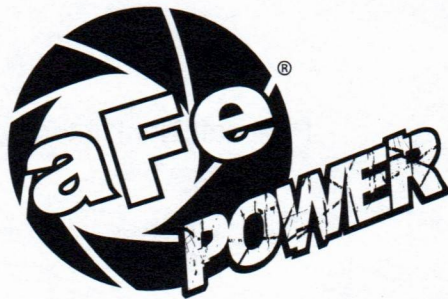

advanced FLOW engineering, inc.

Corona, CA 92879

<https://afepower.com/contact>