

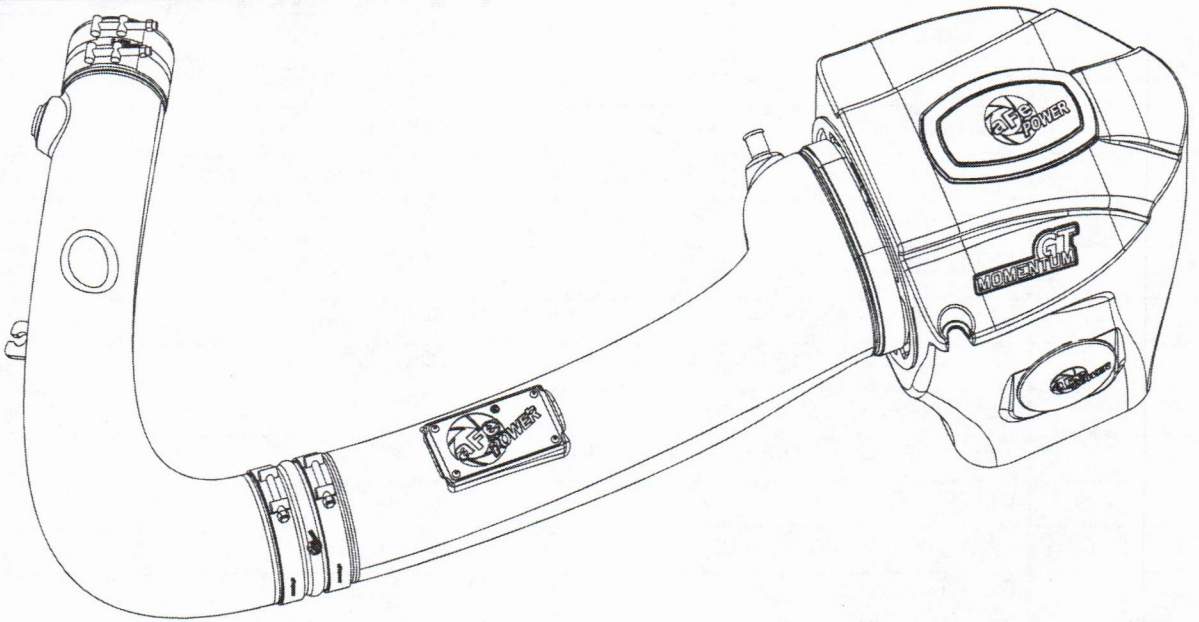

**GT
MOMENTUM™**



advanced FLOW engineering

Cold Air Intake System

Instruction Manual P/N: 51-72201 / 54-72201

Make: **Dodge** Model: **Challenger** Year: **2011-2023** Engine: **V6-3.6L**

Make: **Dodge** Model: **Charger** Year: **2011-2023** Engine: **V6-3.6L**

Make: **Chrysler** Model: **300** Year: **2011-2014** Engine: **V6-3.6L**

NOTE: Excluding Challenger/Charger 2020 Engine Test Group LCRXV03.65P3



- Please read the entire instruction manual before proceeding.
- Ensure all components listed are present.
- If you are missing any of the components, call customer support at 951-493-7185.
- Ensure you have all necessary tools before proceeding.
- Do not attempt to work on your vehicle when the engine is hot.
- Retain factory parts for future use.

Label	Qty.	Description	Part Number
A1	1	Air Filter (Pro DRY S)	21-91092 (Grey Media)
A2	1	Air Filter (Pro-5R)	24-91092 (Blue Media)
B	1	Intake Tube #1	05-72201B1
C	1	Intake Tube #2	05-72201B3
D	1	Housing	05-72201B2
E	2	Clamp, T-bolt (4-1/8"-4-1/2")	03-50262
F	2	Clamp, T-bolt (3-5/16" - 3-5/8")	03-50292
G	1	Clamp-Mini (9/16" - 1-1/16")	03-50078
H	1	Coupling, Silicone Straight	05-01223
I	1	Coupling, Silicone Hump	05-01332
J	1	Bracket, Aluminum Support	05-01369
K	2	Screw, Btn Head Socket	03-50102
L	1	Seal, Trim; 3/4" Bulb, 15/64" Edge (21")	05-01507
M	1	Grommet	03-50167
N	1	Fitting, Air Temp Sensor	05-01454
O	1	Plug, Housing	05-01361
P	1	Mount, rubber	03-50652
Q	1	Hose, Breather: 1/2" ID x 27" L	05-01422

Tools needed: Tools needed: 8mm and 10mm nut driver or socket, flat screw driver, and pliers.

Warranty Information available at: <https://afepower.com/contact#warranty>

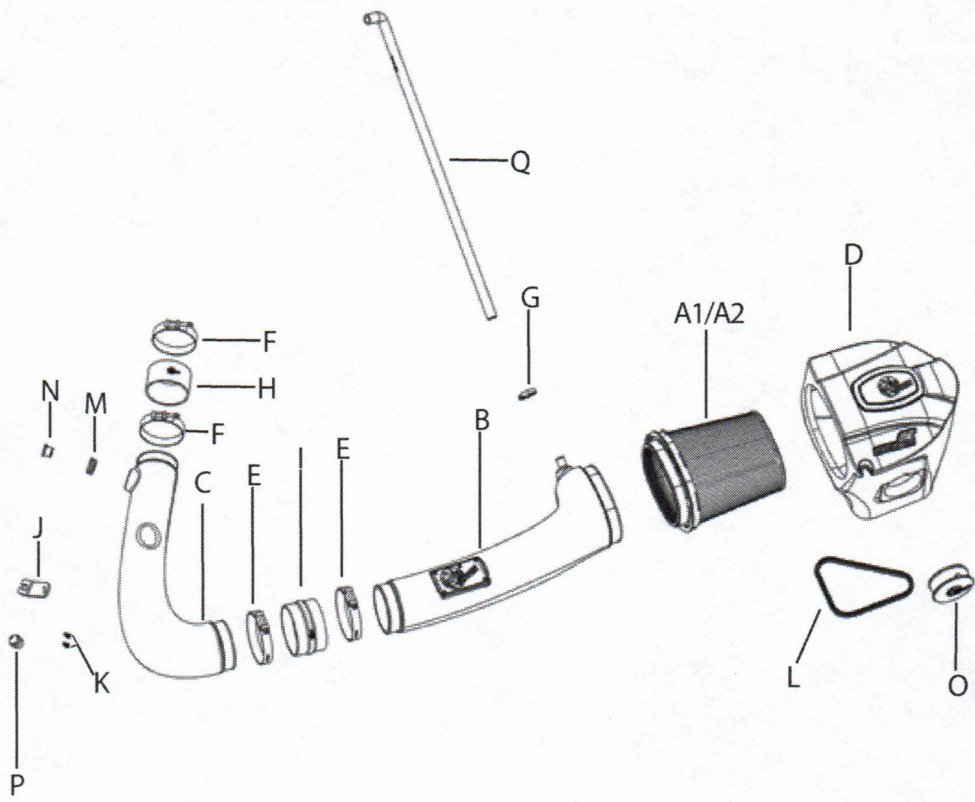

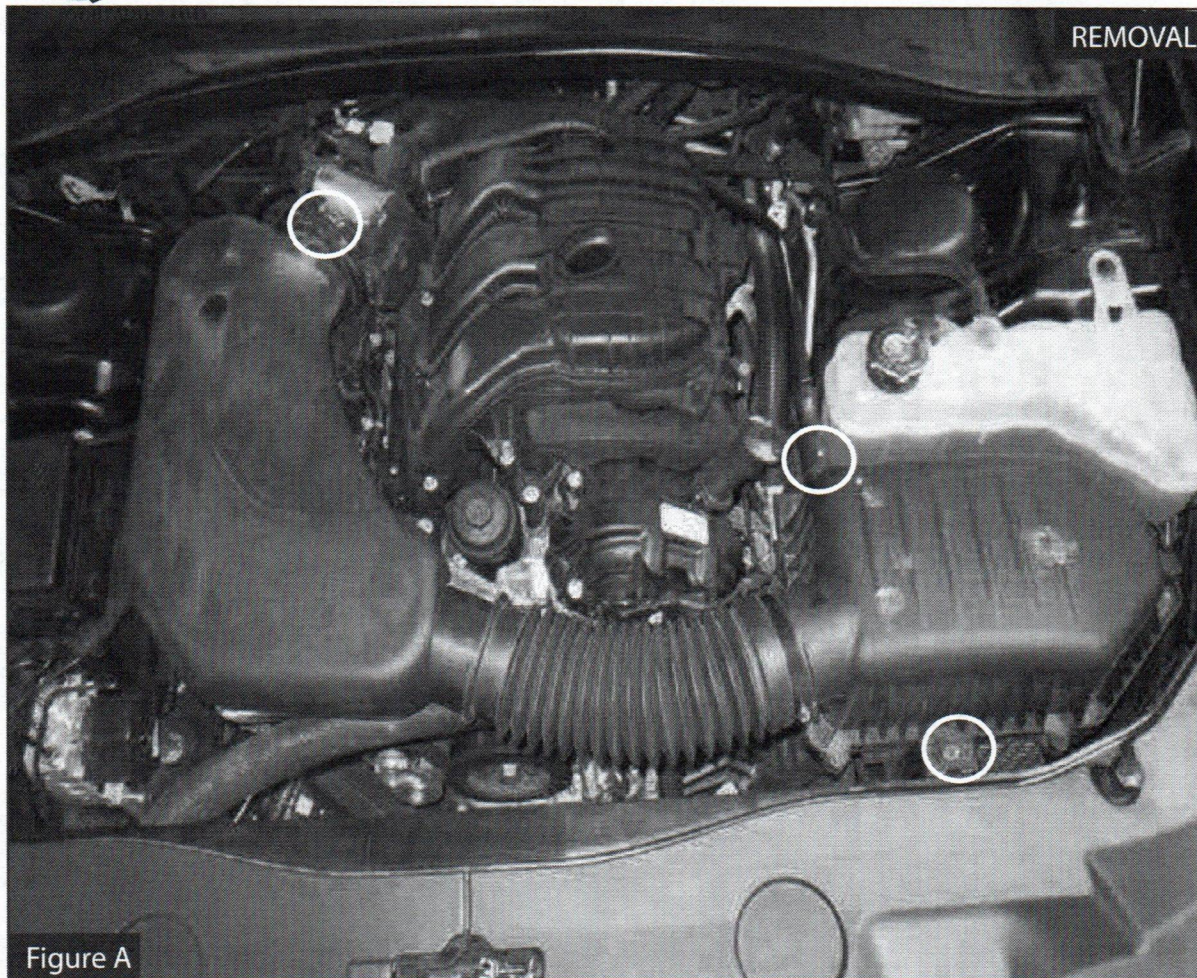

Refer to Figure A for Steps 1-5

Step 1: Remove the engine cover and disconnect the crank case hose.

On 2011-2019 vehicles, crank case hose is located by the air box.

On 2020+ vehicles, it is next to the throttle body.

Step 2: Remove 8mm bolt off the factory air box.

Step 3: Loosen the clamp off the factory intake tube at the throttle body.

Step 4: Unplug Temp sensor.

Step 5: Pull the factory intake air system out of the vehicle.



Figure B

Refer to Figure B for Steps 6-8

Step 6: Transfer the grommet from the factory air box to the aFe housing.

Step 7: Install the trim seal on the bottom edge of the aFe housing.

Step 8: Slide the aFe filter inside the aFe housing until it locks in place. Install clamp on the filter end but do not tighten at this time

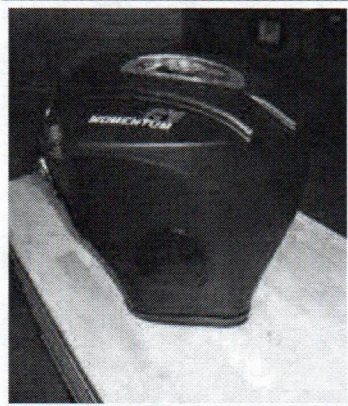

Figure C

Refer to Figure C for Step 9

Step 9: For the 2015 Challenger, if you wish to use the headlight inlet duct, pop the cap off the center of the headlight and install on the aFe housing the aFe inlet duct (Sold Separately, P/N: 54-72203-S). For all other vehicle, leave the housing inlet open to get more air or close it off with the furnished plug to block off the hot engine air.

REMOVAL

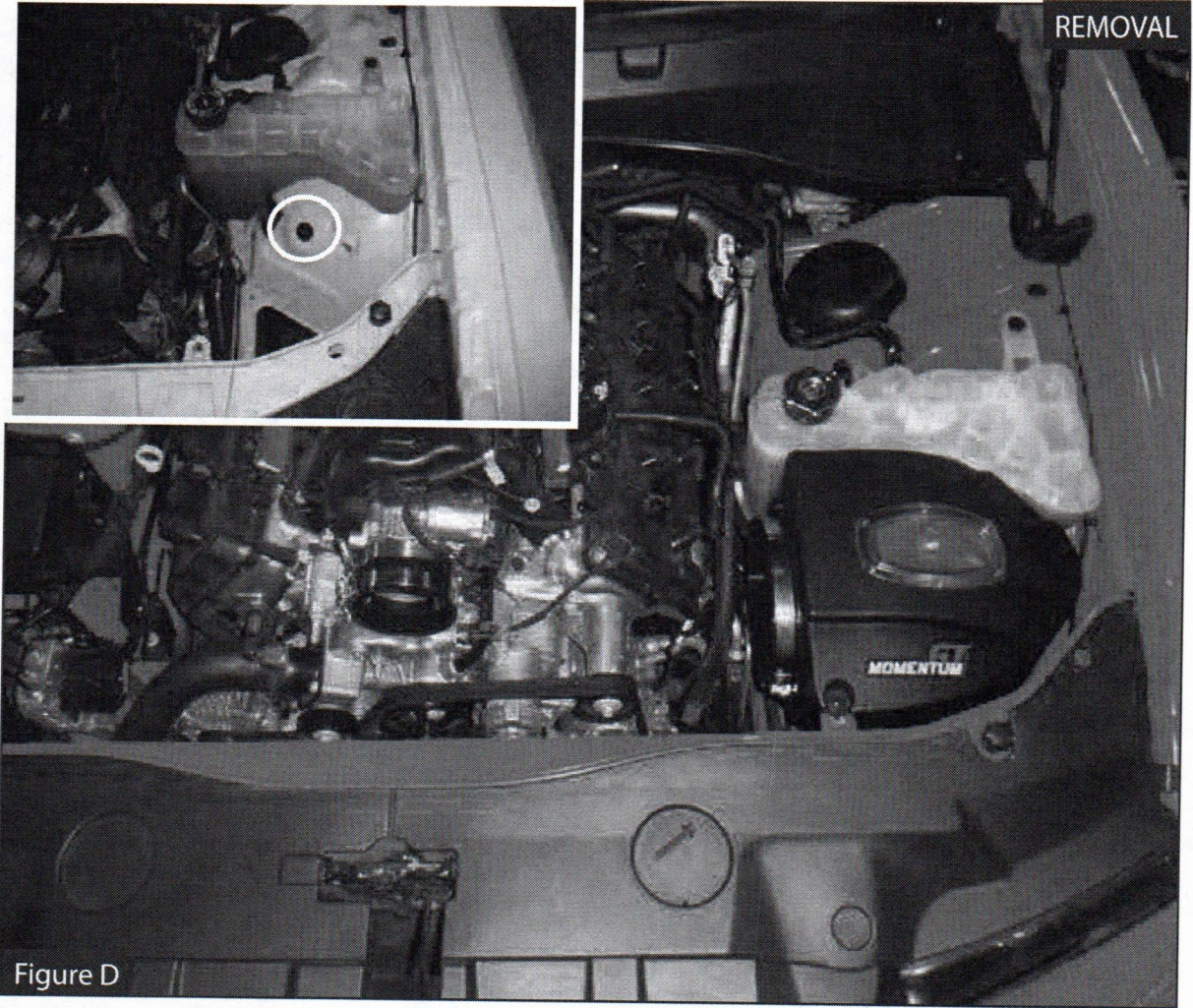
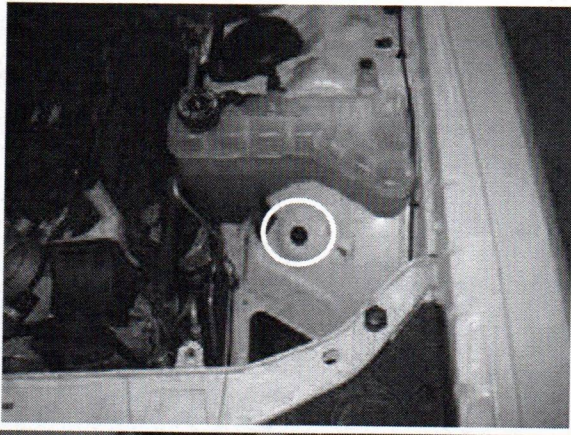
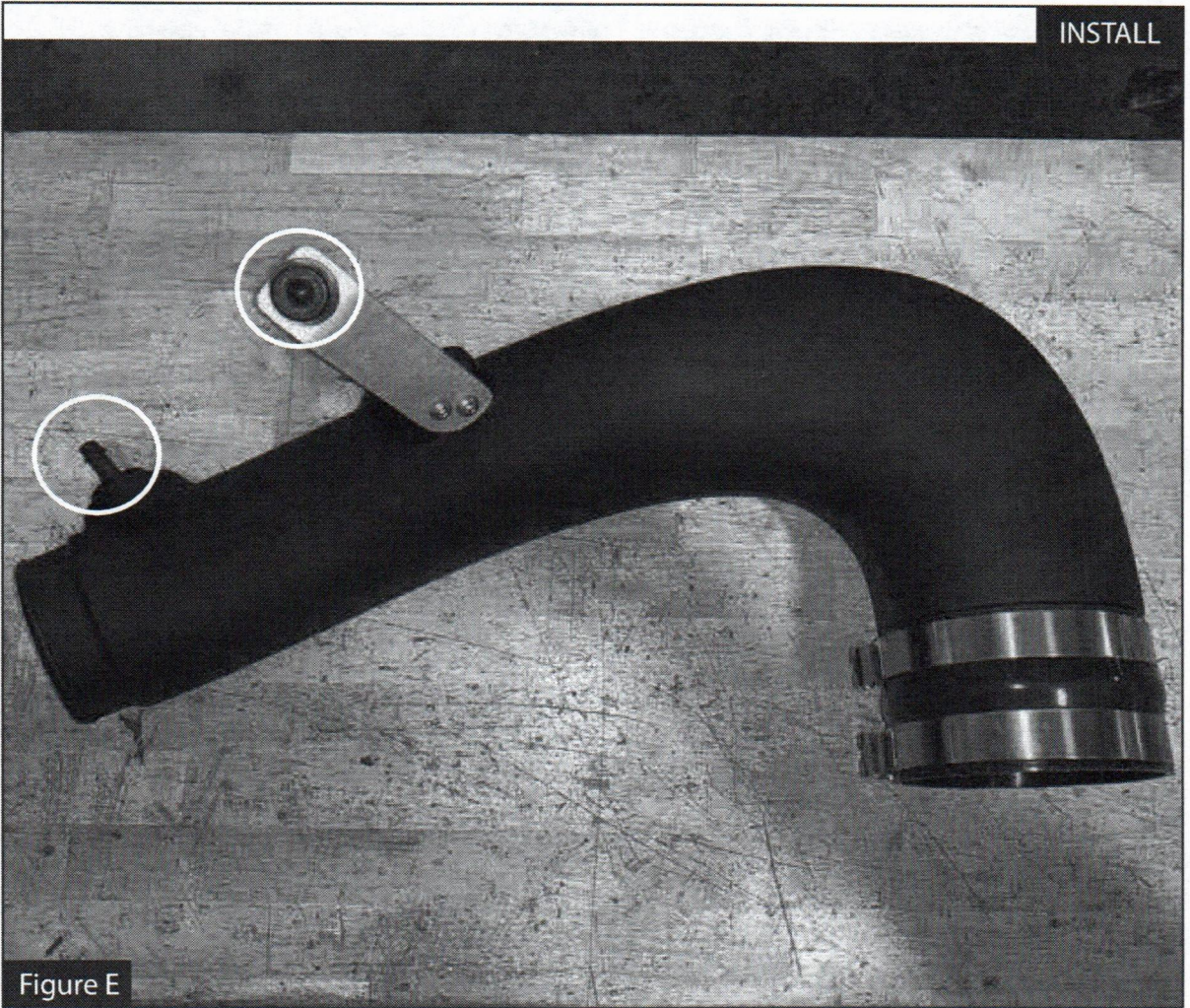

Figure D

Refer to Figure D for Steps 10-11

Step 10: Make sure factory grommet is installed correctly into hole.

Step 11: Install aFe housing assembly into vehicle.



Refer to Figure E for Steps 12-16

- Step 12: Install the hump coupling onto the curved tube with the clamps. Do not tighten yet.
- Step 13: Secure the bracket to the tube using the furnished button head screws. Tighten the screws.
- Step 14: Install the provided rubber mount into to the hole on the bracket.
- Step 15: Install the furnished grommet into hole in aFe tube then press the fitting in it.
- Step 16: Remove the temperature sensor from the factory tube. Secure it into the fitting turning clockwise.

INSTALL

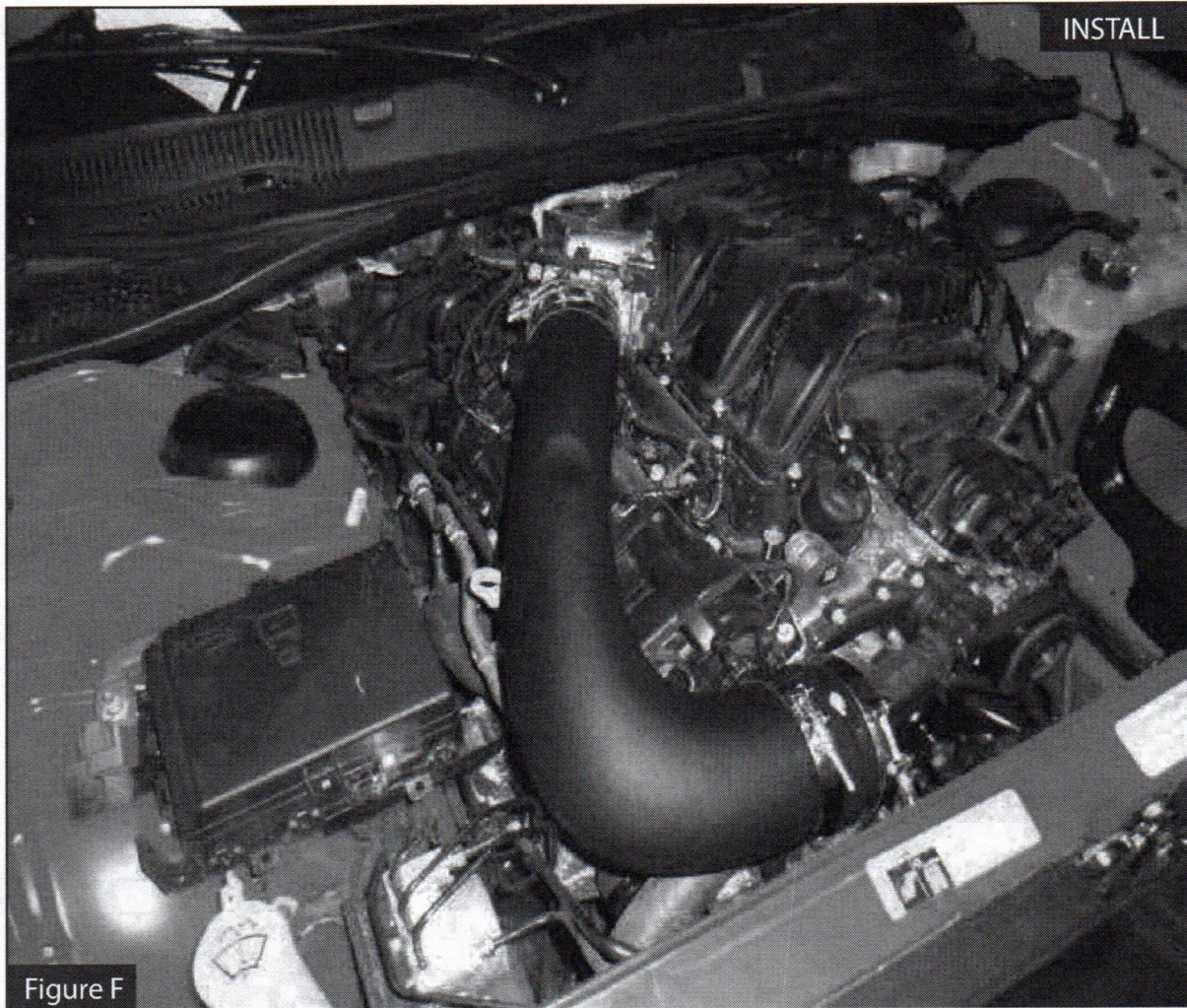

Figure F

Refer to Figure F for Steps 17-18

Step 17: Install the small coupling over the throttle body with clamps. Do not tighten yet.

Step 18: Install the curved tube onto the coupling and push the grommet onto the factory mounting peg.

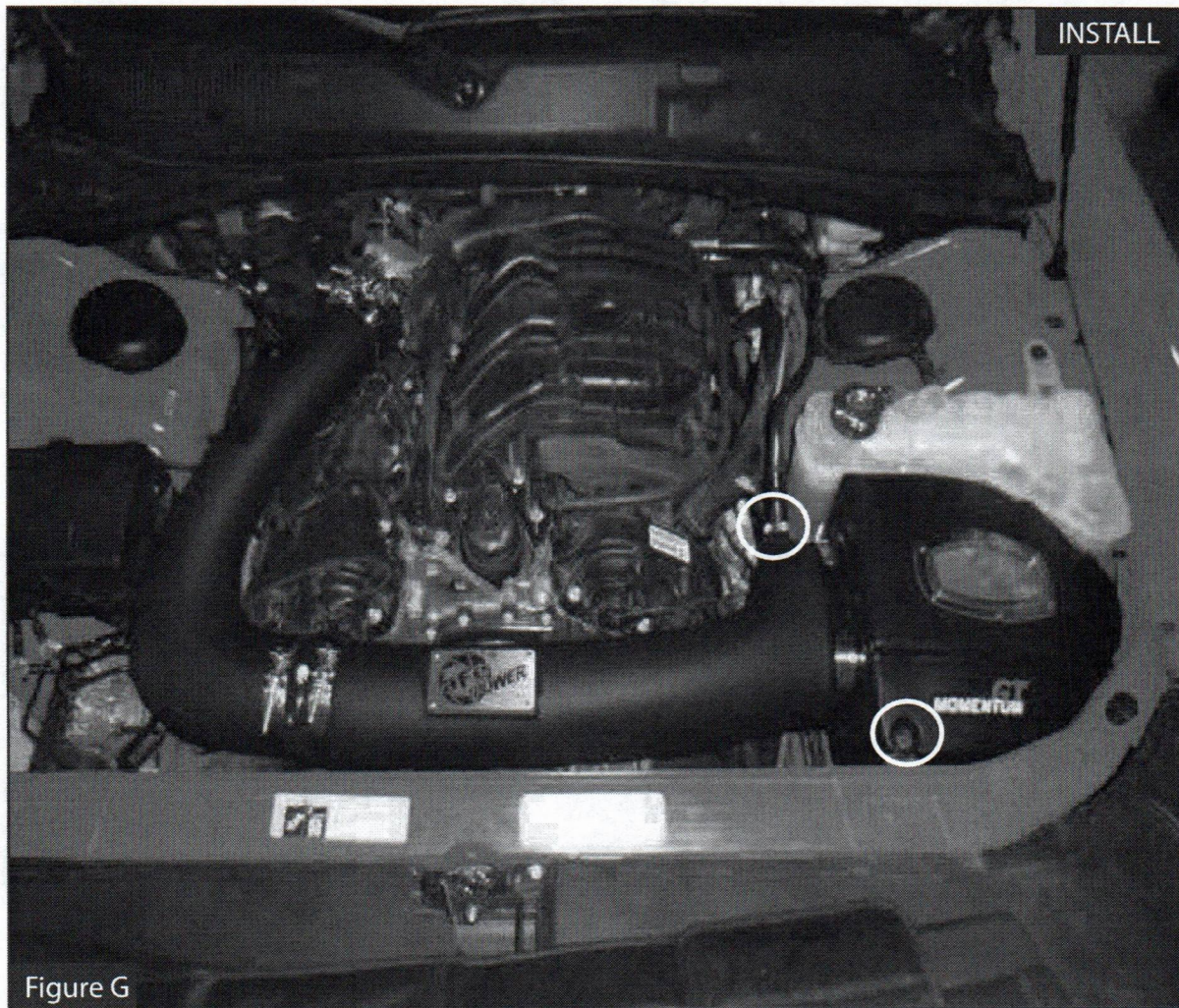

Figure G

Refer to Figure G for Steps 19-23

Step 19: Install the second tube into the filter then into the coupling.

Step 20: Align the tubes correctly, make sure grommet is engaged on mounting peg then tighten all clamps.

Step 21: Reconnect the temperature sensor.

Step 22: For 2011-2019 vehicles, reconnect the crank case hose to the tube and secure it with the furnished mini clamp.

Step 23: Re-install the factory bolt to secure the housing.

INSTALL

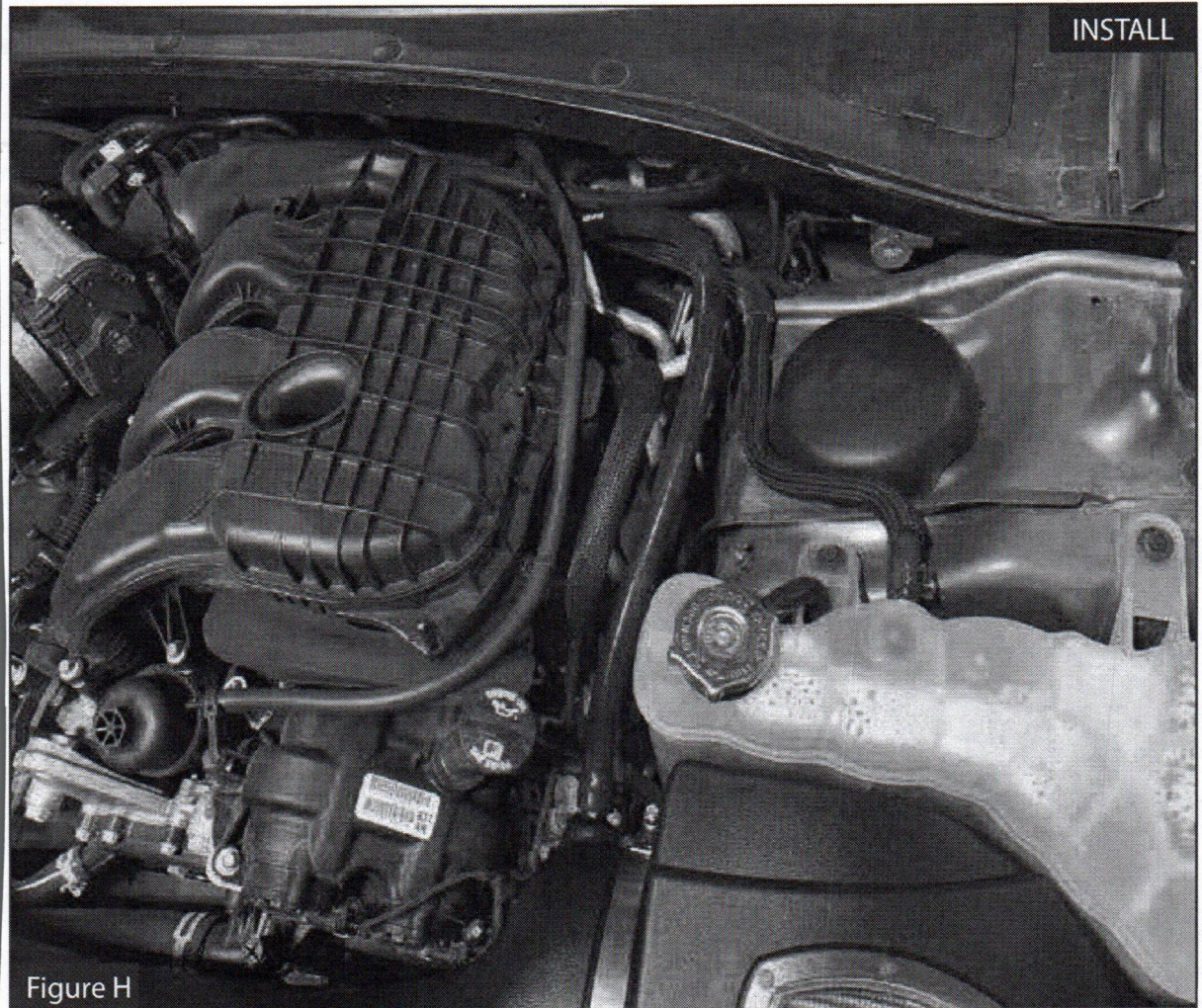

Figure H

Refer to Figure H for Steps 24-25

Step 24: For 2020+ vehicles, disconnect the crank case hose from the back of the engine, by the firewall.

Step 25: Replace that hose with the provided hose. Route it on the driver side and connect it to the aFe tube.

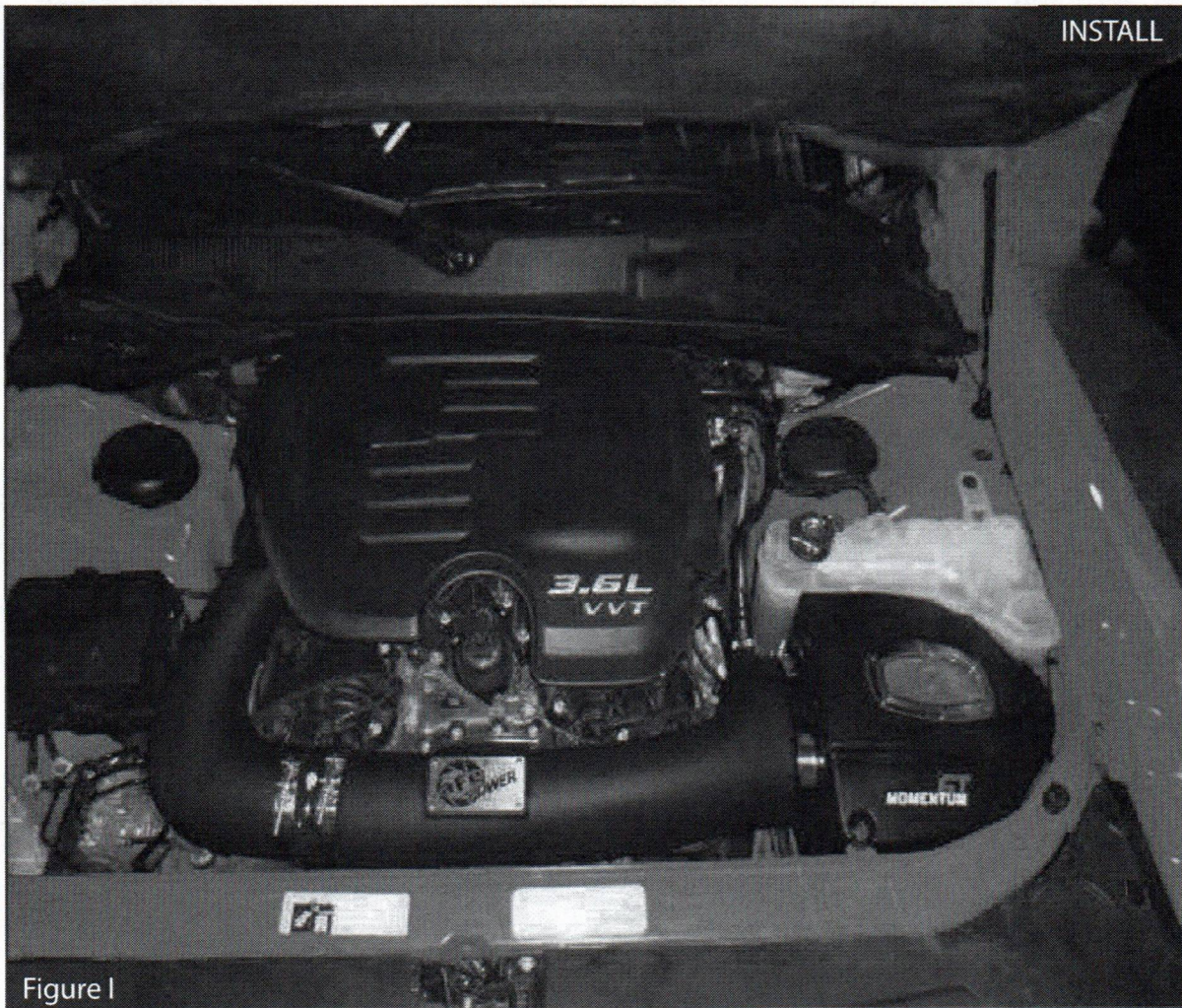

Figure 1

Refer to Figure 1 for Step 26

Step 26: Reinstall the engine cover.

NOTE: Place enclosed CARB EO sticker on a smooth/clean surface on or near the air intake system.
EO identification label is required to pass the smog check inspection.
Your installation is now complete. Thank you for choosing aFePower.

Page left blank intentionally

Page left blank intentionally

Page left blank intentionally



advanced FLOW engineering, inc.

Corona, CA 92879

<https://afepower.com/contact>