

## advanced FLOW engineering

Magnum FORCE Stage-2 Air Intake System

### **Instruction Manual** P/N: 54-12172 / 51-12172

Make: **Dodge**

Model: **Challenger SRT-8/SRT 392**

Year: **2011-2021**

Engine: **V8-6.4L HEMI**

Make: **Dodge**

Model: **Charger SRT-8/SRT 392**

Year: **2011-2021**

Engine: **V8-6.4L HEMI**

Make: **Chrysler**

Model: **300 SRT-8/SRT**

Year: **2012-2014**

Engine: **V8-6.4L HEMI**



- Please read the entire instruction manual before proceeding.
- Ensure all components listed are present.
- If you are missing any of the components, call customer support at 951-493-7100.
- Ensure you have all necessary tools before proceeding.
- Do not attempt to work on your vehicle when the engine is hot.
- Disconnect the negative battery terminal before proceeding.
- Retain factory parts for future use.

Label	Qty.	Description	Part Number
A1	1	Pro 5R (Blue Media)	24-91035 (Blue Media) 54-12172
A2	1	Pro DRY S (White Media)	21-90038 (Grey Media) 51-12172
B	1	Tube	05-12172B1
C	1	Housing	05-12172B2
D	1	Silicone Coupling	05-01193
E	1	Isolation Mount M6	03-50206
F	1	Trim Seal (12.5 Inches)	05-00149
G	3	Lock Washer M6	03-50071
H	3	Screw Hex M6	03-50052
I	3	Flat Washer M6	03-50070
J	1	Grommet	03-50033
K	1	Hose 3/4" (6.50 Inches)	05-00070
L	1	Seal Trim (16.5 Inches)	05-00072
M	1	Seal Trim (25 Inches)	05-00072
N	1	T-bolt Clamp	03-50265
O	1	Isolation Pad	03-50196

Warranty Information available at: <https://afepower.com/contact#warranty>

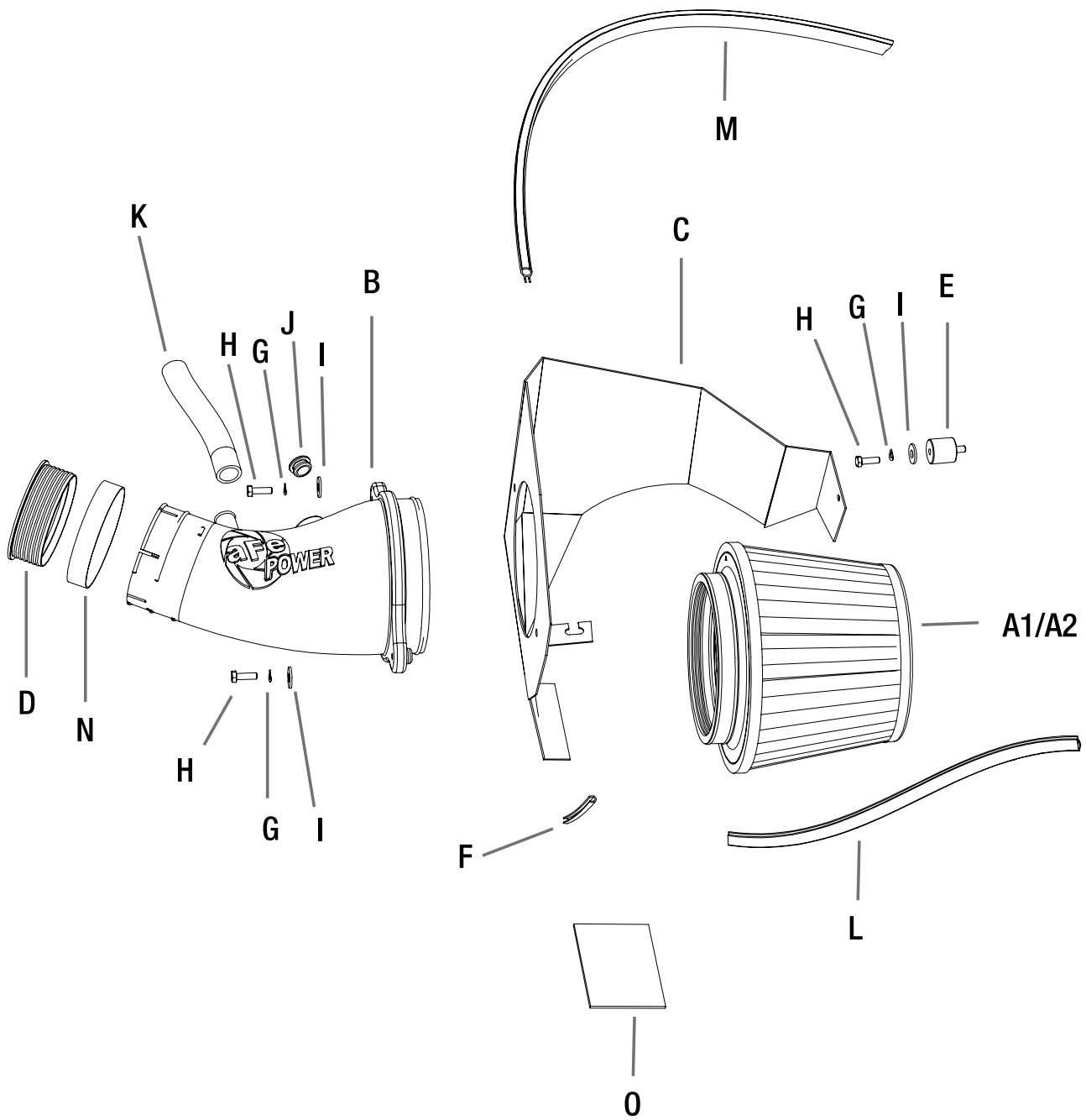

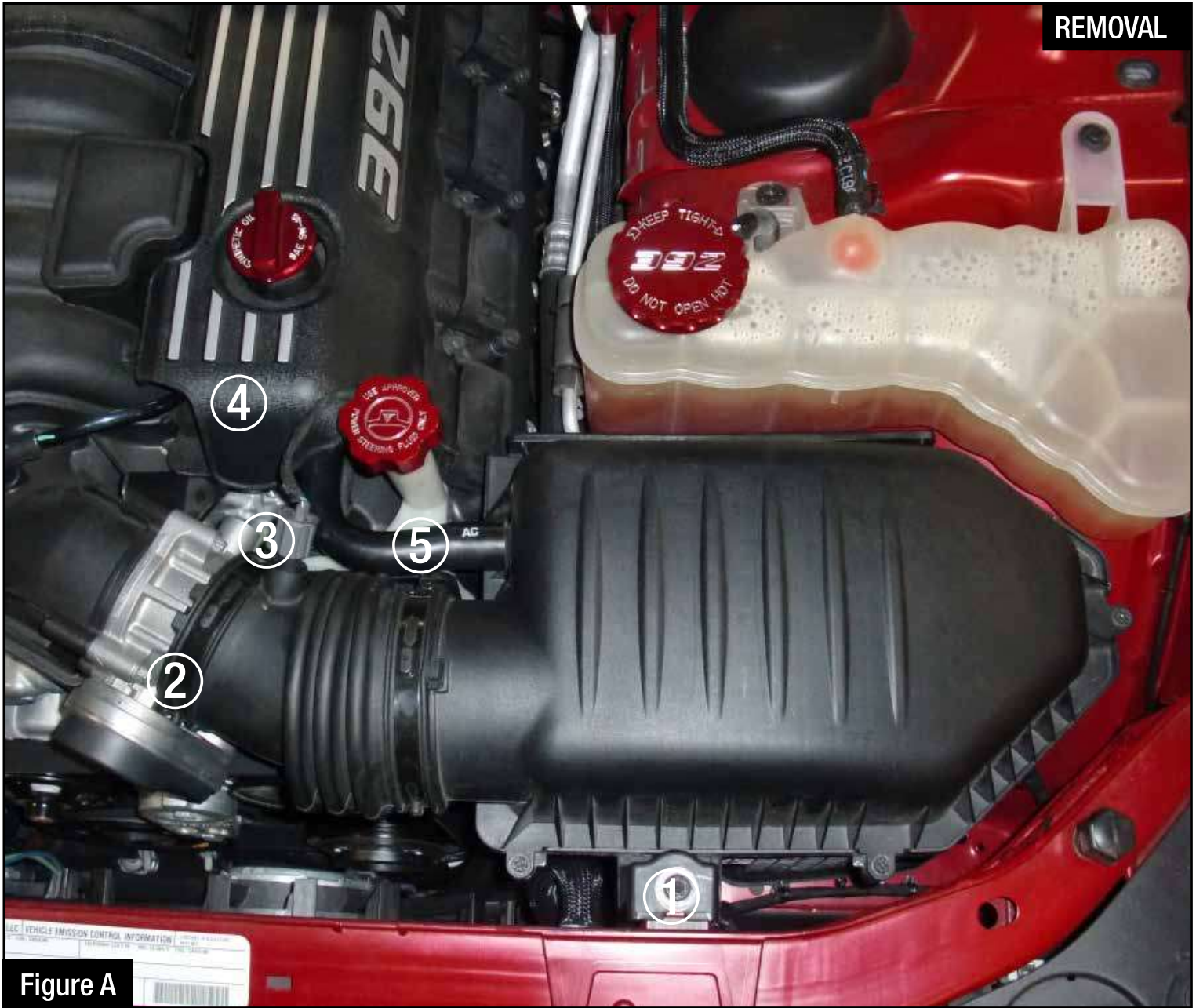

**Refer to Figure A for step 1-5**

- Step 1: Remove the 8mm bolt off the OE air box (1).
- Step 2: Loosen the clamp off the OE intake tube (2).
- Step 3: Unplug the temp sensor (3).
- Step 4: Remove the driverside engine valve cover (4) and remove the crank case hose (5).
- Step 5: Remove the OE airbox out of the vehicle.



Figure B

**Refer to Figure B for steps 6-7**

Step 6: Remove the 10mm bolt from the fender side ⑥.

Step 7: Install the furnished isolation mount into the hole from step 6.



Figure C

**Refer to Figure C for steps 8-11**

Step 8: Remove the OE grommet and metal insert from the OE housing (7).

Step 9: Install the OE grommet and metal insert onto the aFe housing (8).

Step 10: Install the furnished seal trim onto the outer edge of the aFe housing and install foam pad where housing rests (9).

Step 11: Install the aFe housing into the vehicle.



Figure D

**Refer to Figure D for steps 12-14**

Step 12: Install the furnished silicone coupling onto the throttle body (10).

Step 13: Install the furnished grommet onto the aFe intake tube and place the T-bolt clamp onto the throttle body side of the aFe intake tube.

Step 14: Install the aFe intake tube into the vehicle (11) using the furnished hardware.

**Figure E****Refer to Figure E for steps 15-19**

- Step 15: Remove temp sensor from the OE intake tube and install it into the aFe tube.
- Step 16: Install the crank case hose onto the aFe intake tube using the furnished hose.
- Step 17: Install the air filter onto the aFe intake tube with the furnished clamp.
- Step 18: Tighten all connections and reinstall the valve cover removed in step 4.
- Step 19. Your installation is now complete!

**NOTE: Retighten all connections after approximately 100-200 miles.  
Place enclosed CARB EO sticker on or near the device on a smooth, clean surface.  
EO identification label is required to pass the smog inspection.**



Page left blank intentionally



Page left blank intentionally

Page left blank intentionally

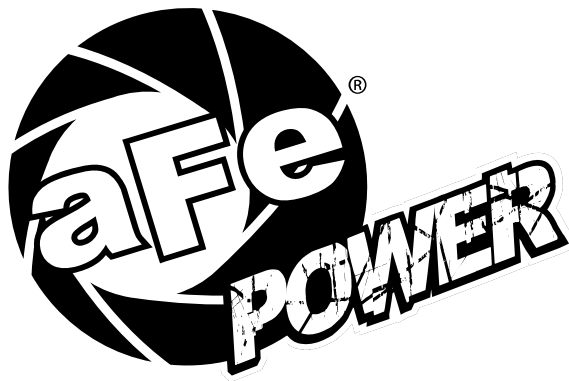

**advanced FLOW engineering, inc.**

252 Granite Street Corona, CA 92879

TEL: 951.493.7100 • TECH: 951.493.7185

E-Mail: [Tech@aFepower.com](mailto:Tech@aFepower.com)

P/N: 06-80433