

## Installation for Ford Mustang 5.0L

PNs: 60662, 60750, & 60752



**\*\*\*\*\* Please compare the parts in the box with the bill of materials provided \*\*\*\*\*  
to assure that you have all the parts necessary for this installation.**

These instructions have been written to help you with the installation of your Borla Performance Exhaust System. Please read this document completely before beginning the installation of your system.

To ensure this part number fits your specific model year, please visit our website for the latest model year listings at [www.BORLA.com](http://www.BORLA.com)

**Thank you for purchasing a Borla Performance Exhaust Component.**

**Borla Performance Exhaust Component PN 60662 is designed for the 2015-2023 Ford Mustang GT, equipped with a 5.0L V8 normally-aspirated engine and RWD automatic or manual transmission.**

**Borla Performance Exhaust Component PN 60750 is designed for the 2024+ Ford Mustang GT & Ford Mustang Dark Horse, equipped with a 5.0L V8 normally-aspirated engine and RWD automatic or manual transmission.**

**Borla Performance Exhaust Component PN 60752 is designed for the 2015+ Ford Mustang GT & 2024+ Ford Mustang Dark Horse, equipped with a 5.0L V8 normally-aspirated engine and RWD automatic or manual transmission.**

Borla Performance Industries recommends that an exhaust shop or professional after market parts installer, who has all the necessary equipment, tools and experienced personnel needed for proper installation, should perform the installation of this system. However, if you decide to perform the installation, we recommend someone should help you. Ensure the installer uses all under car safety precautions including eye protection.

*Please take time to read and understand the following...*

By installing your Borla Performance Exhaust Component, you indicate that you have read this document and you agree with the terms stated below.

It is the responsibility of the purchaser to follow all installation instruction guidelines and safety procedures supplied with your Borla Performance Exhaust Component.

Borla Performance Industries assumes no responsibility for damages occurring from misuse, abuse, improper installation, improper operation, lack of responsible care, or all previously stated reasons resulting from incompatibility with other manufacturer's products and/or systems.

Included with your Borla Performance Exhaust Component is a warranty card. Please read it carefully before you begin any work on your vehicle. If you should have any questions regarding our warranty policy, installation, or any other matter pertaining to your new Borla Performance Exhaust System, please give us a call at the number provided on the warranty card.

**Minimum Required Tool List:**

**TOOLS:**

1. 3/8" drive ratchet
2. 3/8" drive extension 6"
3. 15mm deep well socket
4. Reciprocating Saw with metal cutting blade

5. Pry bar

**SHOP SUPPLIES:**

1. Spray lubricant

**Borla Performance - Bill of Materials**

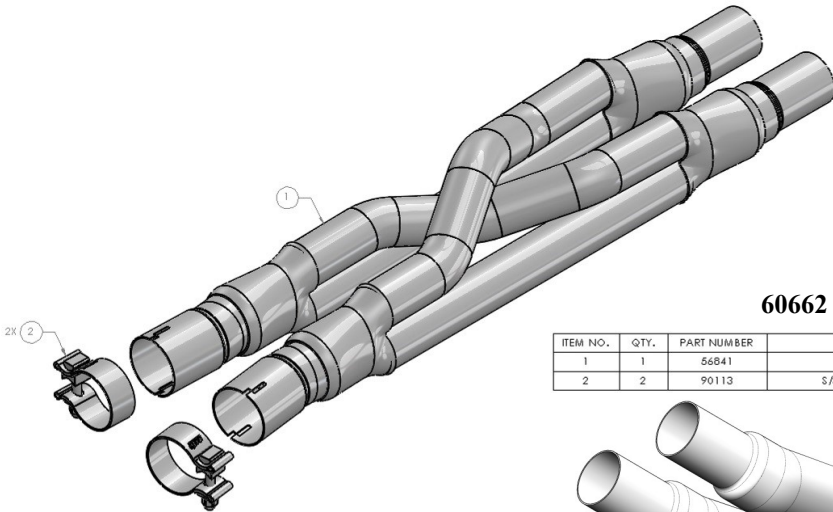

**60662**

ITEM NO.	QTY.	PART NUMBER	DESCRIPTION
1	1	56841	X-PIPE ASSEMBLY
2	2	90113	S/S ACCUSEAL CLAMP Ø2.50

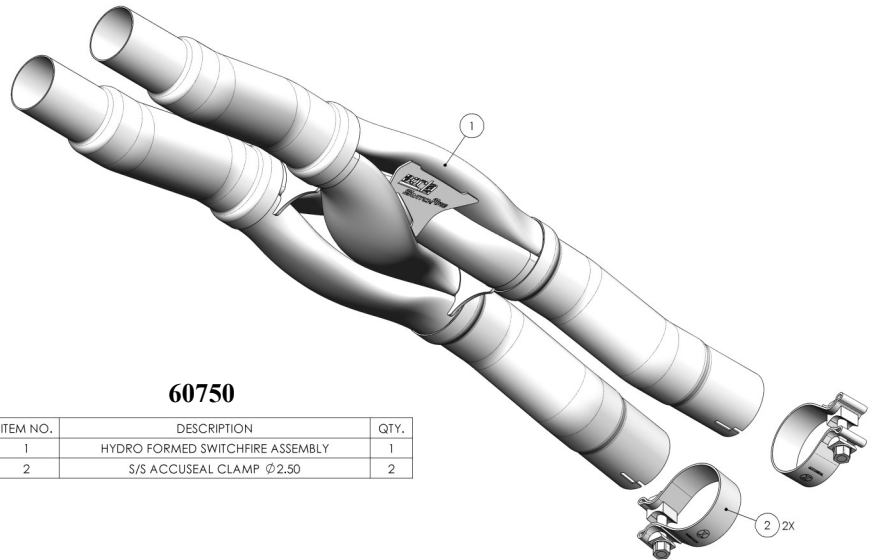

**60750**

ITEM NO.	DESCRIPTION	QTY.
1	HYDRO FORMED SWITCHFIRE ASSEMBLY	1
2	S/S ACCUSEAL CLAMP Ø2.50	2

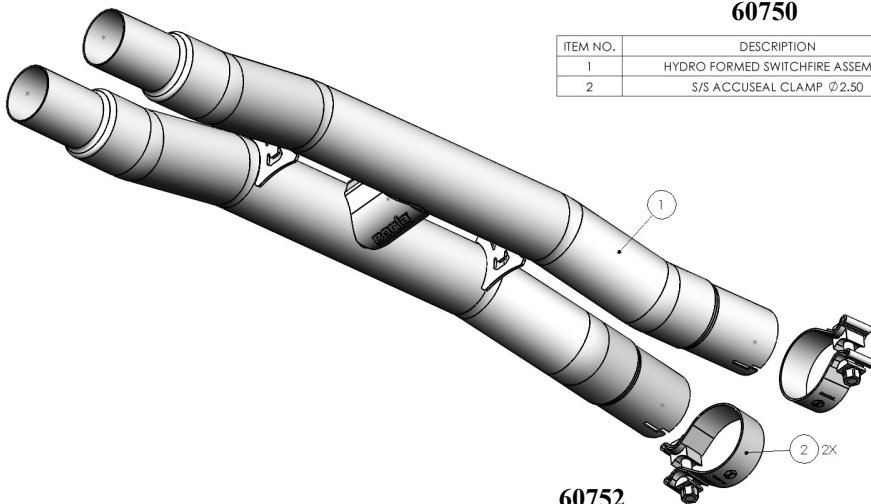

**60752**

ITEM NO.	DESCRIPTION	QTY.
1	H-PIPE ASSEMBLY	1
2	S/S ACCUSEAL CLAMP Ø2.50	2

**Caution!!!** *Never work on a hot exhaust system. Serious injury in the form of burns can result if the vehicle has been in use and the exhaust system is hot, allow vehicle to cool for at least 1 hour. Always wear eye protection when working under any vehicle.*

**Note:** *It is our recommendation that you use a hoist or hydraulic lift to facilitate the installation of your new Borla Performance Exhaust System.*

**Taking all under car safety precautions, lift the vehicle using a hoist or hydraulic lift. Once this has been done, you may begin the removal of your old exhaust system from your vehicle.**

**Note:** *Before removing the original exhaust system from your vehicle, please compare the parts you have received with the bill of materials provided on the previous page to assure that you have all the parts necessary for the installation of your new Borla Performance Exhaust System.*

**Note:** *With a used vehicle, we suggest a penetrating spray lubricant to be applied liberally to all exhaust fasteners and allowing a significant period of time for the chemical to lubricate the threads before attempting to disassemble.*

## Original Exhaust System Removal

1. Using a flathead screwdriver or a prybar, lift and release the tabs on the sleeve clamps. Then loosen the hardware on the clamps and slide them toward the front of the vehicle (Fig. 1).
2. Loosen and remove the hardware connecting the intermediate pipe assembly isolators to the vehicle and lift and release the isolators from the vehicle (Fig. 2). Save this hardware for reinstallation.
3. Not Pictured: For vehicles with Active Valve Performance Exhaust, unplug the electrical connector and remove the wiring harness from the bracket.
4. Using a muffler stand or an additional person, lower the front of the exhaust system and slide the assembly forward releasing the mufflers from their isolators, and remove from the vehicle (Fig. 3).
5. Original exhaust system removed (Fig. 4).

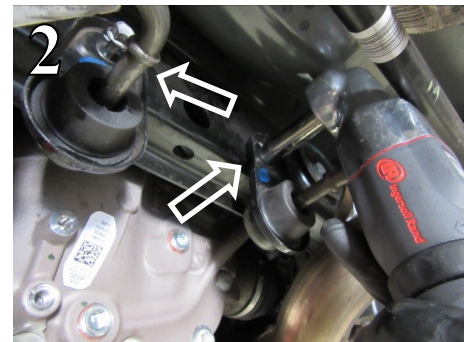
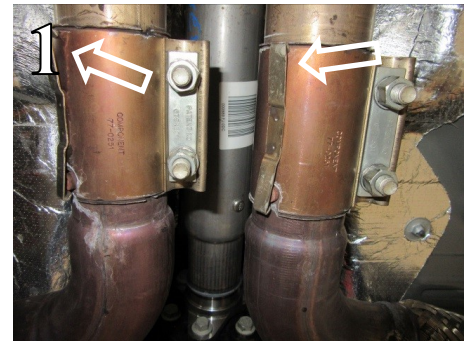

## Borla Performance Exhaust System Installation

1. Make a mark and cut using a reciprocating saw with a metal cutting blade 4 3/8" from each of the outlets of the original resonator (Figs. 5-6).
2. Insert the inlets of the **Borla Crossover Assembly** into the original sleeve clamps (Figs. 7-8). Do not tighten the clamps.
3. Place a clamp over the driver's side expanded end of the **Borla Crossover Assembly**. Reinstall the original rear muffler assembly to the vehicle and insert the inlet to the expanded end of the **Borla Crossover Assembly**. Do not tighten the clamp.
4. Repeat Step 3 for installation of the passenger side rear muffler assembly.
5. For vehicles with the Active Valve Performance Exhaust, reconnect the wire harness to the actuator and attach the harness clip to the actuator bracket.
6. Once position has been determined to be correct, first tighten the original sleeve clamps and then tighten the Accuseal clamps to 32-35 ft. lbs.
7. Before starting your vehicle, make sure to check all wires, hoses, brake lines, body parts and tires for safe clearance from the exhaust system.
8. Start the vehicle and check for any leaks. If any leaks are found, determine cause (such as loose or incorrectly positioned clamp) and repair as necessary.

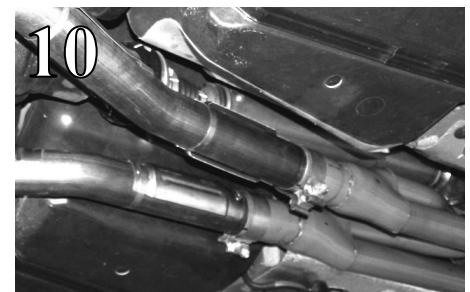
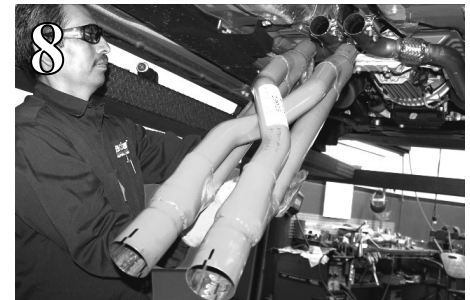
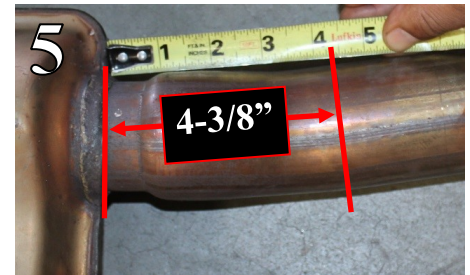

**WARNING:** Use extreme caution during installation. Torque all fasteners according to manufacturer's torque values and tightening sequence. **DO NOT** use air impact tools to tighten fasteners on Borla Performance Exhaust Systems. Use of such tools may result in bent flanges or gasket contact areas leading to exhaust leaks.

**NOTE:** When you first start your vehicle after the installation of your new Borla Performance Exhaust System, there may be some smoke and fumes coming from the system. This is a protective oil based coating used in the manufacturing of mandrel bent performance exhaust tubing. This is not a problem and will disappear within a very short period of time after the exhaust has reached normal operating temperatures.