

OPEN FIRST!!

Parts list for Kit # 4.1138

2011+ Ford Mustang w/ MT-82 Trans

ENERGY
SUSPENSION 

1131 VIA CALLEJON, SAN CLEMENTE, CA 92673

© 2015 Energy Suspension. All rights reserved.
May not be reproduced, in any form, or by any means,
without the written consent of Energy Suspension.

It is recommended that if you are unfamiliar with this type of work that you refer to a qualified service center specializing in this type of work. It is also recommended that if you choose to do this work yourself that a factory service manual be obtained for the proper procedures pertaining to removal, replacement and proper torque specifications for your vehicle. This instruction set is intended as a guideline for the safe installation of Energy Suspension's polyurethane bushings, once you have removed the factory components from your vehicle. Wheel alignment is almost always disturbed when suspension components are removed or replaced. It is recommended that you have the alignment checked on your vehicle at a qualified alignment shop. Energy Suspension recommends that you read over all the installation instructions and check all P/N's and quantities in the parts list before you start. Call customer service at 949-361-3935 if the parts in your kit do not match this parts list. Prior to installation, make sure that your car is in excellent mechanical condition and that there are no suspension or steering related problems. This part has been designed to work only with a car that is in good state of repair. No matter how carefully we design our parts, this is one area we have no control over and cannot be held responsible.

Parts list:

Transmission Mount Insert

- 1 - 01P01335 Transmission Insert
- 1 - 01P01338 Insert Retainer

Please refer to our newest catalog for more information on custom applications including bump stops, shock bushings, universal mounts, tie rod boots, ball joint boots, transmission mounts, Formula 5 Prelube etc. Please ask to see our catalog at your place of purchase.

Installation Instructions:

Support the transmission at stock height using an engine jack or floor jack (Pic 1). Once the position of the transmission is secure, remove the four bolts which secure the crossmember to the body and the two bolts that secure the crossmember to the transmission mount (Pic 2). Press the Transmission Insert (01P01335) from the front of the vehicle towards the rear into the three voids of the O.E. transmission mount (Pic 3). With the Transmission Insert installed completely against the mount, press the Insert Retainer (01P01338) into the holes of the Transmission Insert (01P01335) from the rear of the vehicle towards the front (Pic 4). Once both the insert and retainer are in place, reinstall the cross member and secure the transmission mount (Pic 5). Tighten the bolts to the factory recommended torque.



17P17648

16/APR/15 JLS ECN 15043

OPEN FIRST!



1131 VIA CALLEJON, SAN CLEMENTE, CA 92673

Installation Instructions

4.1145 2015+ Ford Mustang GT

4.1134 2011-14 Ford Mustang

Manual Transmission Shifter Bushing Set

© 2015 Energy Suspension. All rights reserved.

May not be reproduced, in any form, or by any means, without the written consent of Energy Suspension.

It is recommended that if you are unfamiliar with this type of work that you refer to a qualified service center specializing in this type of work. It is also recommended that if you choose to do this work yourself that a factory service manual be obtained for the proper procedures pertaining to removal, replacement and proper torque specifications for your vehicle. This instruction set is intended as a guideline for the safe installation of Energy Suspension's polyurethane bushings, once you have removed the factory components from your vehicle. Wheel alignment is almost always disturbed when suspension components are removed or replaced. It is recommended that you have the alignment checked on your vehicle at a qualified alignment shop. Energy Suspension recommends that you read over all the installation instructions and check all P/N's and quantities in the parts list before you start. Call customer service at 949-361-3935 if the parts in your kit do not match this parts list. Prior to installation, make sure that your vehicle is in top mechanical condition and that there are no suspension or steering related problems. This part has been designed to work only with a vehicle that is in good state of repair. No matter how carefully we design our parts, this is one area we have no control over and cannot be held responsible.

Parts List:

4.1134 1EA 1276

4.1145 1EA 01P01340

1276



01P01340



Footnotes:

(57) Must reuse all metal parts.

(113) With manual transmission

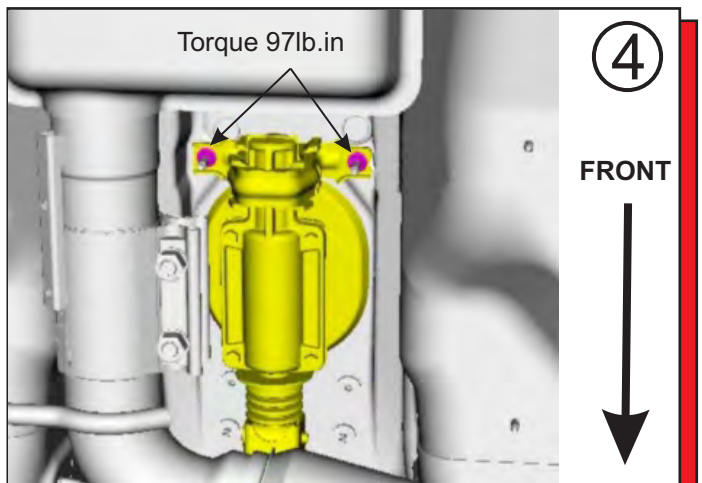
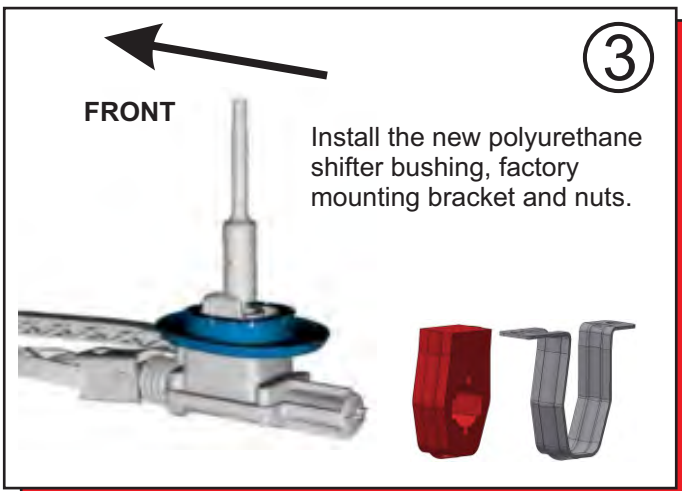
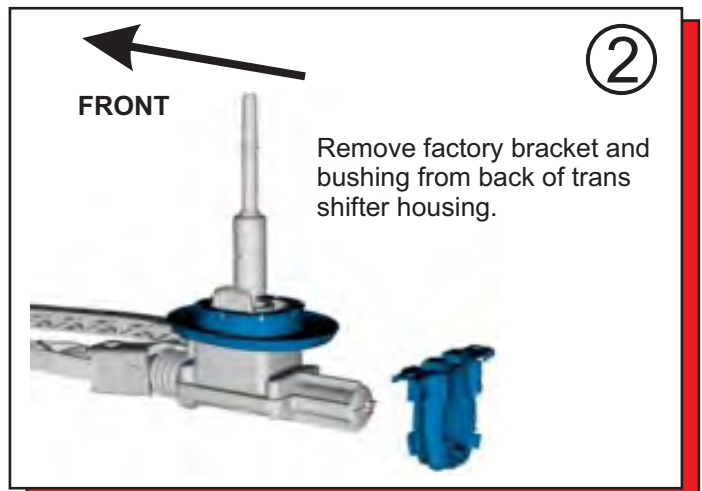
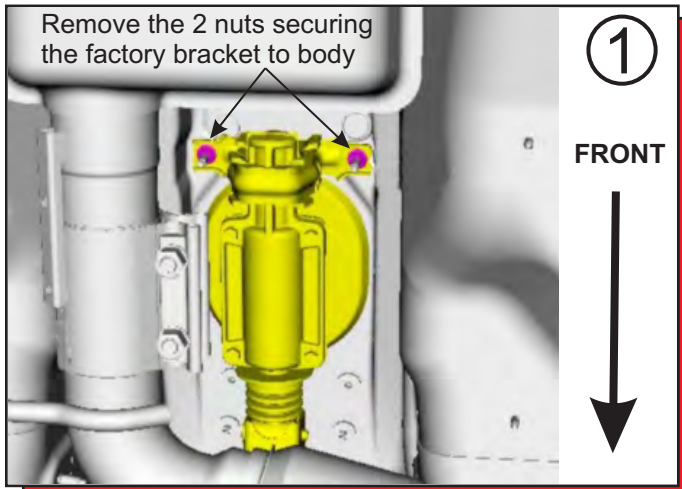

17P17651

14/MAY/15 BRH ECN 15007