

Drain coolant

1. 

 **WARNING:** When releasing the cooling system pressure, cover the coolant expansion tank cap with a thick cloth.

Remove the pressure relief cap.

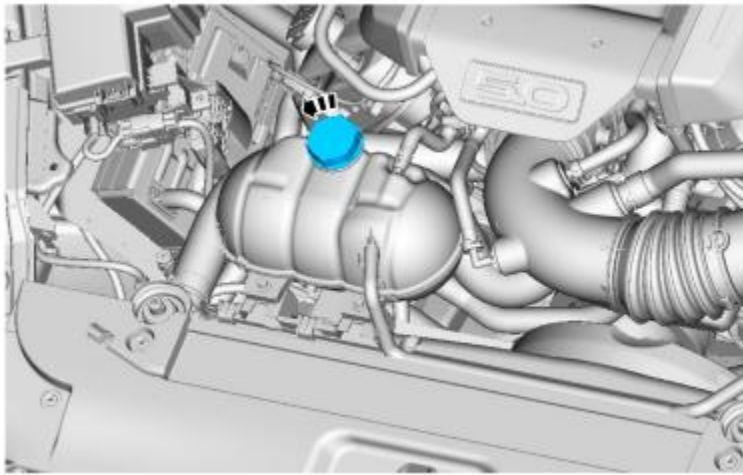

E100626

With the vehicle in NEUTRAL, position it on a hoist.

3. **NOTE:** *If equipped.*

Remove the underbody shield.

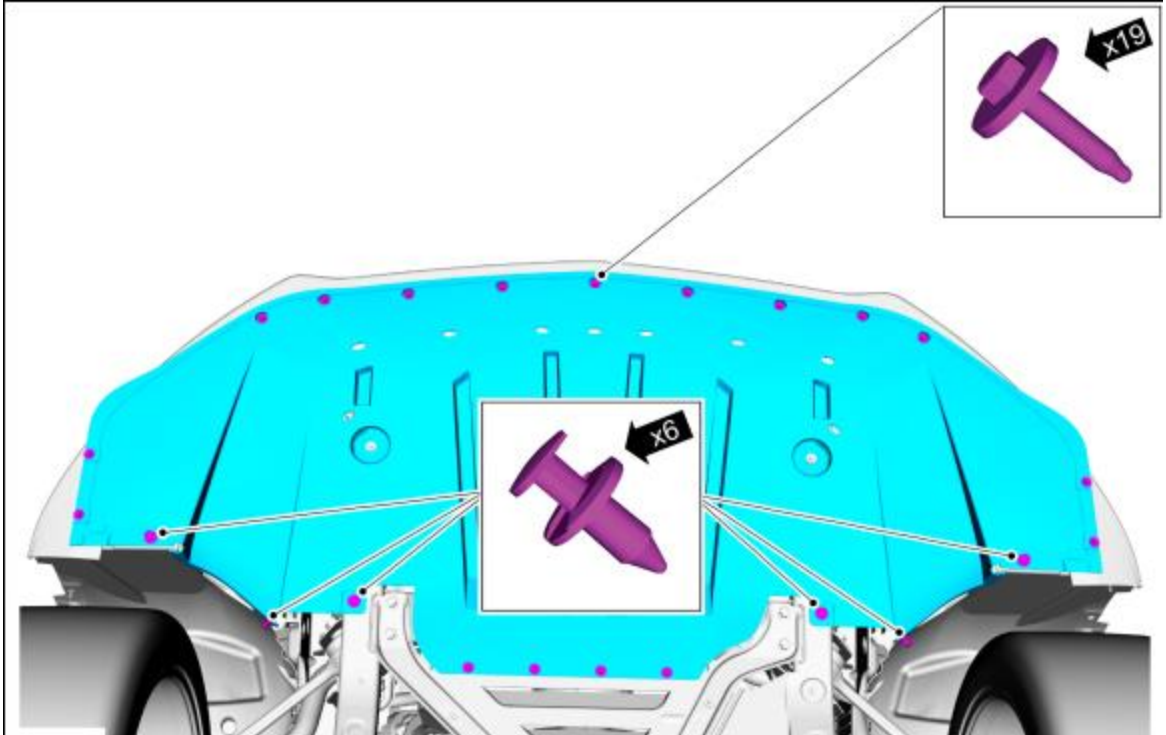

5. 

 **WARNING: Be prepared to collect escaping fluid.**

- Use a hose to drain the coolant.
- Open the radiator drain valve and drain the engine coolant in a suitable, clean container.

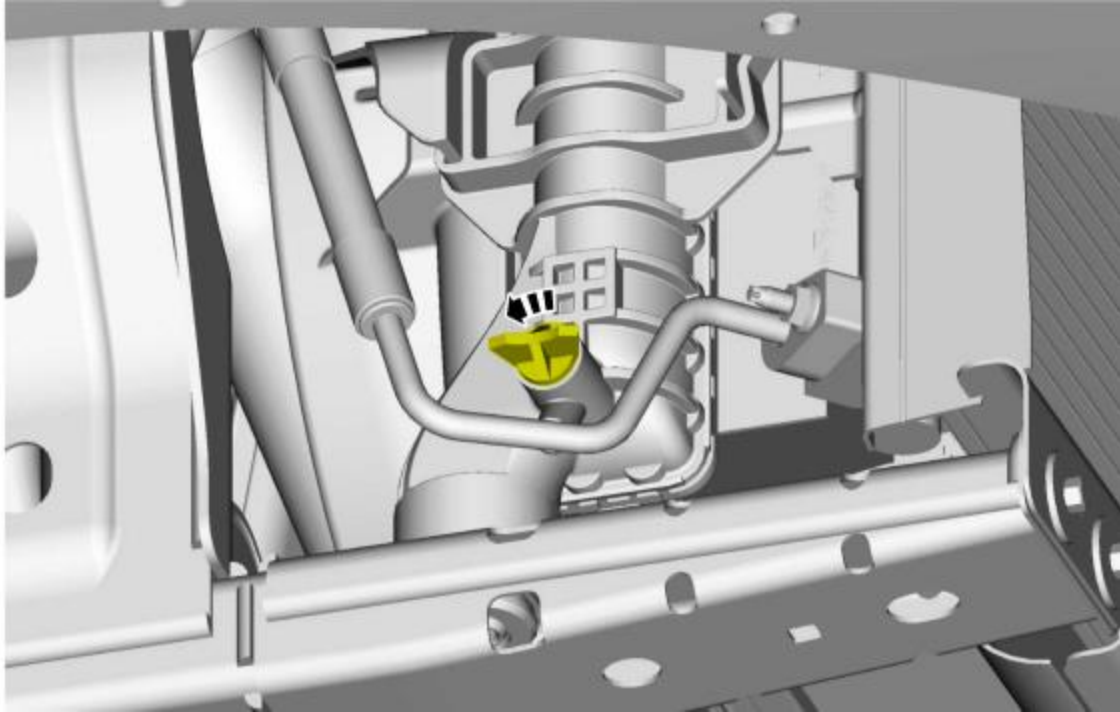

Remove heater hoses

Disconnect the heater core inlet and outlet hoses front and rear.

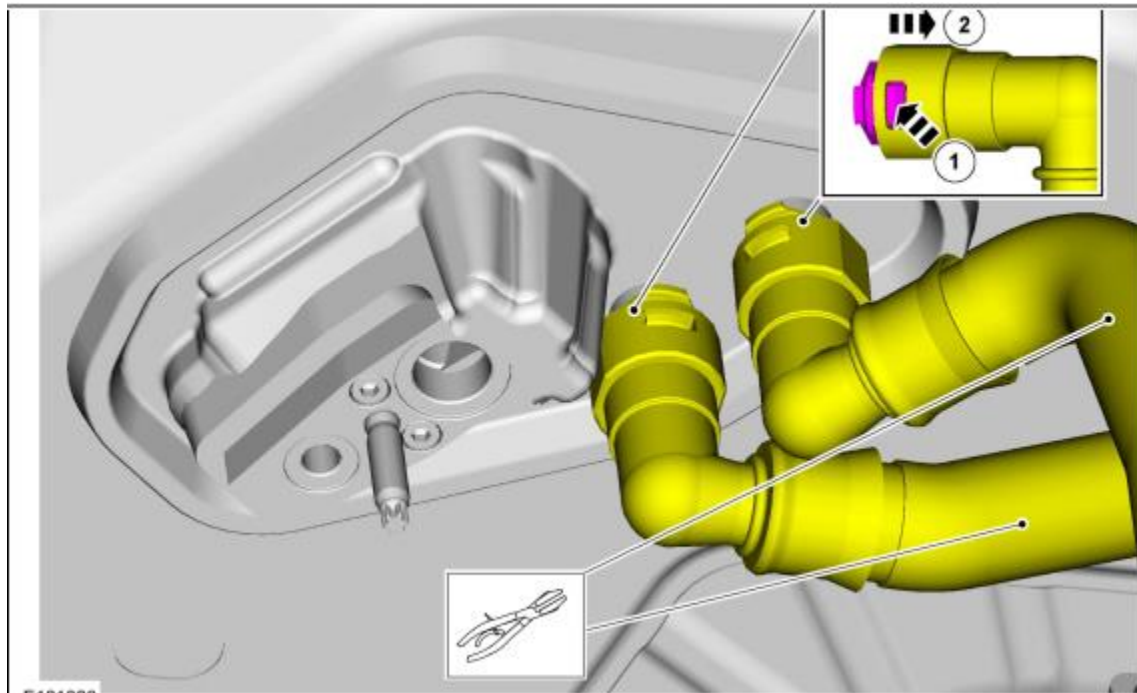

Remove hose supports

Remove the heater hose supports.

Install new hose supports with logo. Torque nuts to 62 lb. in.

LH has a large L on bottom side.

RH has a large R on bottom side.

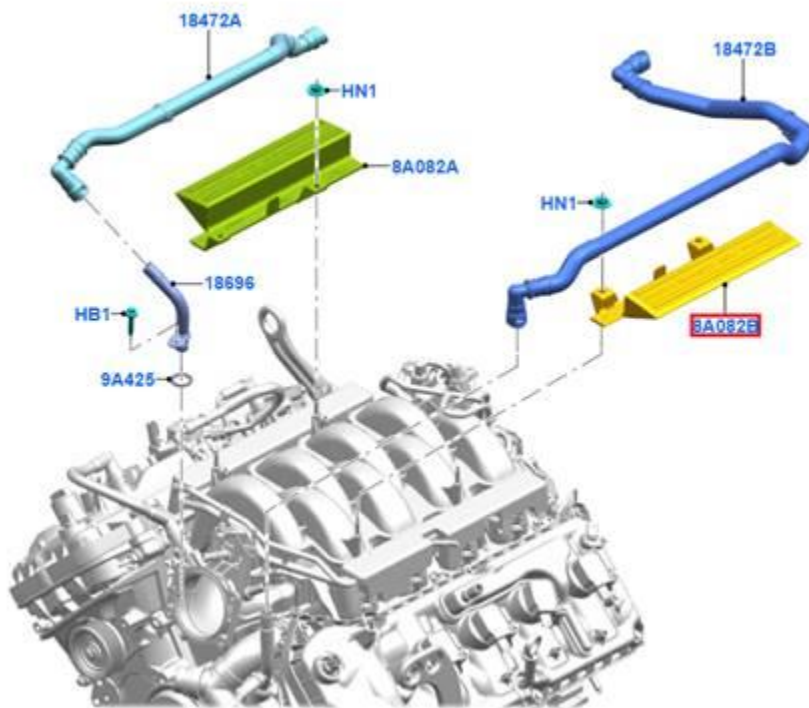

Install new heater hoses

Fill cooling system

Filling

Filling and Bleeding with a Vacuum Cooling System Filler

1.
 - **NOTICE: The cooling system is filled with Motorcraft® Orange Antifreeze/Coolant. Do not mix coolant types. Mixing coolant types degrades the corrosion protection of the coolant. Failure to follow these instructions may damage the engine or cooling system.**

NOTICE: Engine coolant provides boil protection, corrosion protection, freeze protection, and cooling efficiency to the engine and cooling components. In order

to obtain these protections, maintain the engine coolant at the correct concentration and fluid level in the degas bottle.

NOTE: Add Motorcraft® Orange Antifreeze/Coolant or equivalent.

NOTE: Do not add or mix with any other type of engine coolant. Mixing coolants may degrade the coolant's corrosion protection.

NOTE: Do not add alcohol, methanol, or brine, or any engine coolants mixed with alcohol or methanol antifreeze. These can cause engine damage from overheating or freezing.

NOTE: Ford Motor Company does NOT recommend the use of recycled engine coolant in vehicles originally equipped with Motorcraft® Orange Antifreeze/Coolant since a Ford-approved recycling process is not yet available.

When adding or topping off the engine coolant:

- Measure the coolant concentration in the vehicle.
Use Special Service Tool: ROB75240 Coolant/Battery Refractometer (Fahrenheit).
- Determine the concentration desired based on the vehicle duty cycle of extreme hot or cold operating conditions.
- Add, top-off or adjust the coolant as follows:
- For concentrations measured 48/52 to 50/50 (freeze protection -34°C to -37°C [-30°F to -34°F]) use Motorcraft® Orange Antifreeze/Coolant Prediluted to maintain a coolant concentration in this same range.
Material: Motorcraft® Orange Prediluted Antifreeze/Coolant / VC-3DIL-B (WSS-M97B44-D2)
- For all other concentrations, use Motorcraft® Orange Antifreeze/Coolant Concentrated and/or distilled water to get to the desired concentration.
Material: Motorcraft® Orange Concentrated Antifreeze/Coolant / VC-3-B (WSS-M97B44-D)
- When refilling the engine coolant after a flush procedure, use a mixture of Motorcraft® Orange Antifreeze/Coolant Concentrated and distilled water to get to the desired concentration.

2. Close the radiator drain valve.

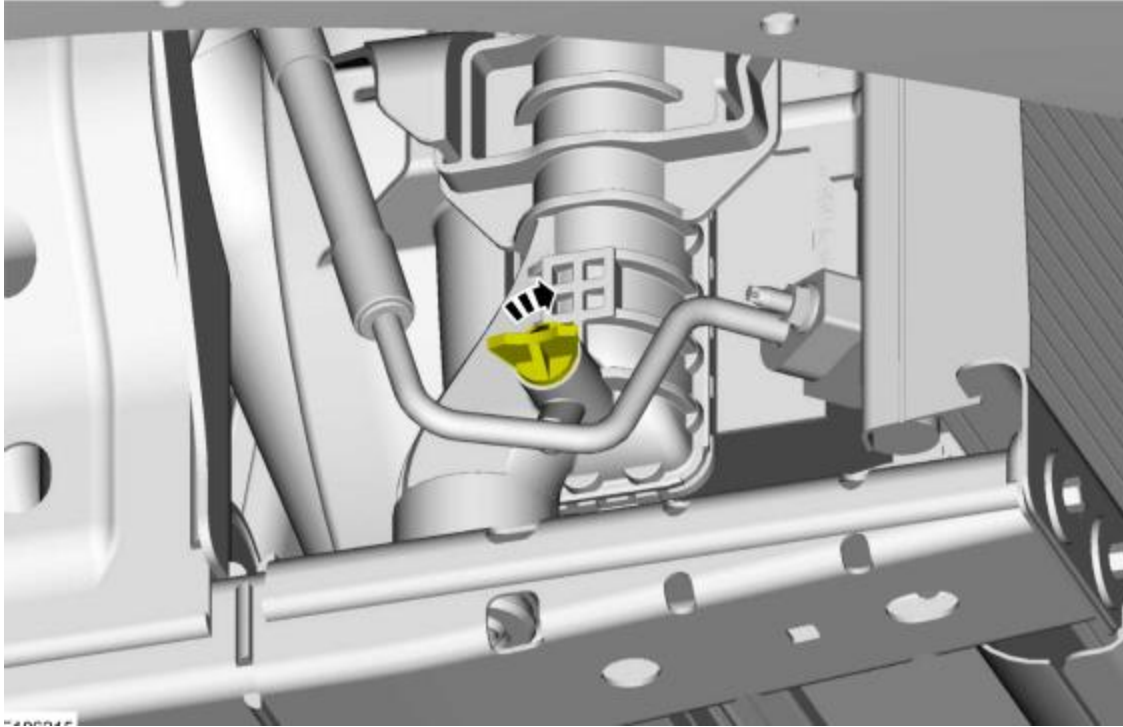

3. **NOTE:** *If equipped.*

Install the underbody shield.

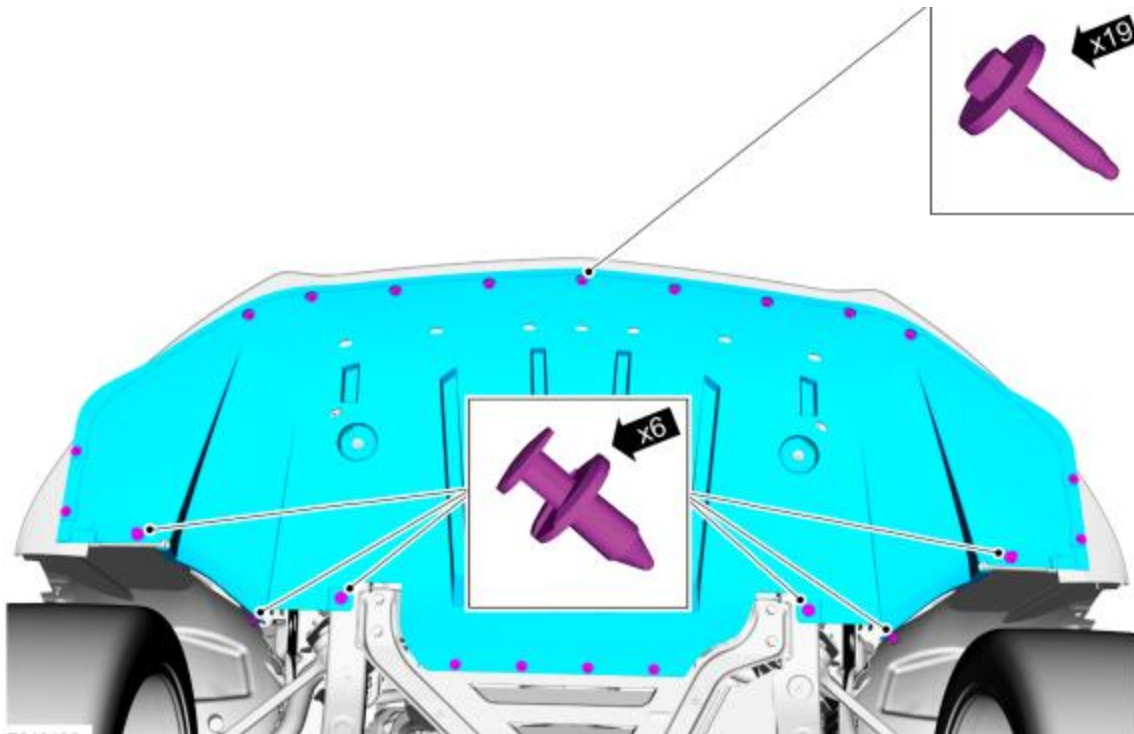

5. Install the vacuum cooling system filler and follow the manufacturer's instructions to fill and bleed the system.
Use the General Equipment: Cooling System Vacuum Tester and Refiller
6. Recommended coolant concentration is 48/52 to 50/50 engine coolant to distilled water (freeze protection -34°C to -37°C [-30°F to -34°F]).
7.
 - For extremely cold climates (less than -37°C [-34°F]):
 - It may be necessary to increase the coolant concentration above 50%.
 - NEVER increase the coolant concentration above 60%.
 - Maximum coolant concentration is 60/40 for cold weather areas.
 - A coolant concentration of 60% provides freeze protection down to -50°C (-58°F)
 - Engine coolant concentrations above 60% will decrease the overheat protection characteristics of the engine coolant and may damage the engine.
8.
 - For extremely hot climates:
 - It is still necessary to maintain the coolant concentration above 40%.
 - NEVER decrease the coolant concentration below 40%.
 - Minimum coolant concentration is 40/60 for warm weather areas.
 - Engine coolant concentrations below 40% will decrease the freeze and corrosion protection characteristics of the engine coolant and may damage the engine.
9. Vehicles driven year-round in non-extreme climates should use a 48/52 to 50/50 (freeze protection -34°C to -37°C [-30°F to -34°F]) mixture of engine coolant and distilled water for optimum cooling system and engine protection.

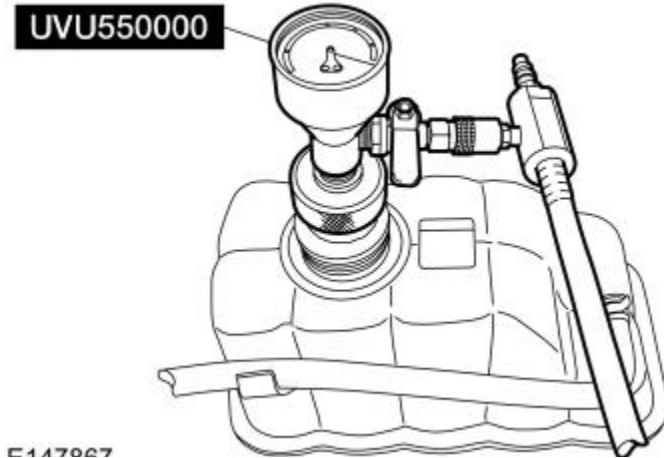

10. Install the degas bottle cap until it contacts the hard stop.
11. Turn the climate control system off.
12. Start the engine and increase the engine speed to 3,500 rpm and hold for 30 seconds.
13. Turn the engine off for and wait for 1 minute to purge any large air pockets from the cooling system.
14. **⚠️ WARNING: Always allow the engine to cool before opening the cooling system. Do not unscrew the coolant pressure relief cap when the engine is operating or the cooling system is hot. The cooling system is under pressure; steam and hot liquid can come out forcefully when the cap is loosened slightly. Failure to follow these instructions may result in serious personal injury.**

Check the engine coolant level in degas bottle and if necessary fill to the top of the MAX FILL line on the degas bottle if the engine is warm or to the top of the MIN FILL LEVEL if the engine is cold.

15. Start the engine and let it idle until the engine reaches normal operating temperature and the thermostat is fully open. A fully open thermostat is verified by the cooling fan cycling on at least once.
16. Increase the engine speed to 3,500 rpm and hold for 30 seconds.
17. Allow the engine to idle for 30 seconds.
18. Turn the engine off for 1 minute.
19. Repeat steps 16 through 18 a total of 10 times to remove any remaining air trapped in the system.
20. **⚠️ WARNING: Always allow the engine to cool before opening the cooling system. Do not unscrew the coolant pressure relief cap when the engine is operating or the cooling system is hot. The cooling system is under pressure; steam and hot liquid can come out**

forcefully when the cap is loosened slightly. Failure to follow these instructions may result in serious personal injury.

Check the engine coolant level in degas bottle and if necessary fill to the top of the MAX FILL line on the degas bottle.

21. Install the pressure relief cap.

