



Blowfish Racing, LLC
200 Old Love Point Road
Stevensville, MD 21666
steve@blowfishracing.com
410-643-1127

V-2 MT82 Shifter Support Kit, 2015+ Mustang (GT/V6/ECOBOOST)

Congratulations on the purchase of your Blowfish Racing, LLC MT82 Shifter Support Kit! You have chosen a quality, American Made product that has been Engineered for the demands of the racing world with style you'll be proud to show off on the street.

Since the release of the MT82 Manual Transmission in the 2011 and up Mustangs, there have been numerous issues reported with regards to shifting quality, gate lockout and synchro failures. None of the shifter products on the market addressed the real issue, so they were largely ineffective. The issue is the semi-remote shifter design. It is great at reducing NVH (Noise Vibration and Harshness), but at the cost of accuracy. The design attaches the front half of the shifter assembly to the transmission and the other half to the body. Under full load engine torque, the engine and transmission rock to one side which attempts to bring the shifter with it, but since the shifter is also attached to the body, it can't move and ends up twisting. This directly effects shifting accuracy and produces gate lockout and gear grinding.

While the stock shifter design was improved for the 2015 (S550) model and shifts better than the previous generation, it is still a semi-remote design. When improving power or simply taxing the vehicle beyond normal driving conditions, the shifter will still have the same issues as the previous generation did.

The Blowfish Racing MT82 Isolation Mount Shifter Support Kit has been designed to reconfigure the semi-remote shifter to a direct mount shifter by removing the body mount and attaching the back of the shifter to the transmission. This allows the shifter assembly to work in sync with the transmission. As the transmission rocks under torque, so does the shifter. This, by nature, is not necessarily NVH friendly. While it will not produce the noise and vibration associated with some stiffer rear shifter mount brackets and transmission mount inserts, it isn't free of NVH. The shifter becomes directly attached to the transmission, so the engine vibrations will transmit. This is normally only a vibration felt in the shift knob. In some rare cases, this may result in faint noise. Unfortunately, there are compromises in any attempt to give the driver a more precise shifting experience.

NOTE: This Kit will not correct a faulty clutch or repair a damaged transmission. If you have a sticking clutch pedal or gear grinding or inoperative gears, you should correct those issues to get the most out of this Shifter Support Kit.

This Kit is designed to work with the various factory shifters utilized between the GT, V6 and EcoBoost models. It will not work with any aftermarket shifter that replaces the entire shifter assembly. The kit eliminates the rear shifter bracket, so those will become paperweights. It will also not work with Driveshaft Safety Loops, but fear not because the bracket is an NHRA legal Driveshaft Safety Loop!

OK, lets install it and get you loving your manual transmission again!

STEP 1: Preparation

READ THESE DIRECTIONS PRIOR TO THE INSTALLATION!

Tools Recommended:

- Jack and Jack Stands
- Wheel Chocks
- 3/8" Drive Ratchet with 15mm Deep Socket
- 3/8" Torque Wrench (ft/lb reading)
- 1/4" Drive Ratchet with 12" Extension
- 1/4" Drive Swivel Joint
- 1/4" Drive 10mm Shallow Socket
- 1/4" Drive 10mm Deep Socket
- 15mm Box End/Ratcheting Box End Wrench

Installation Time Needed: about 1.5 hours

WARNING!! INSTALLATION REQUIRES WORKING AROUND THE EXHAUST. ALLOW THE CAR TO COOL OFF PRIOR TO INSTALLATION TO PREVENT BURNS.

STEP 2: Jack Vehicle Up and Secure it

Jack the vehicle according to the manufacturer's recommended procedures and jacking points. Use wheel chocks to prevent the vehicle from moving.

STEP 3: Rear Shifter Bracket Removal

Locate the shifter bracket under the vehicle, just behind the shifter assembly and above the driveshaft. Using the 10mm DEEP Socket, 12" Extension and 1/4" Ratchet, Remove the (2) Nuts from the Body Studs (FIG 1, RED ARROWS) and then remove the Bracket, allowing the shifter to sag down.

NOTE: To ease installation, it may be helpful to tie a bungee between the shifter knob and the rearview mirror to hold the shifter assembly up after removing the rear mount.

STEP 4: Upper Bracket Placement

Because of space constraints due to the exhaust, it is important to place the Upper Bracket prior to continuing with the installation. It will need to be

positioned with the Isolators above the driveshaft and facing rearward as shown in FIG 2. To get it into position, flip the Bracket upside down and rotate it around the driveshaft. Rotating the Bracket will be easier if done rearward of the shifter and then brought back forward. It will rest as far forward as possible underneath the shifter assembly.

FIG 1-Rear Shifter Mount and Trans Isolator Bolts

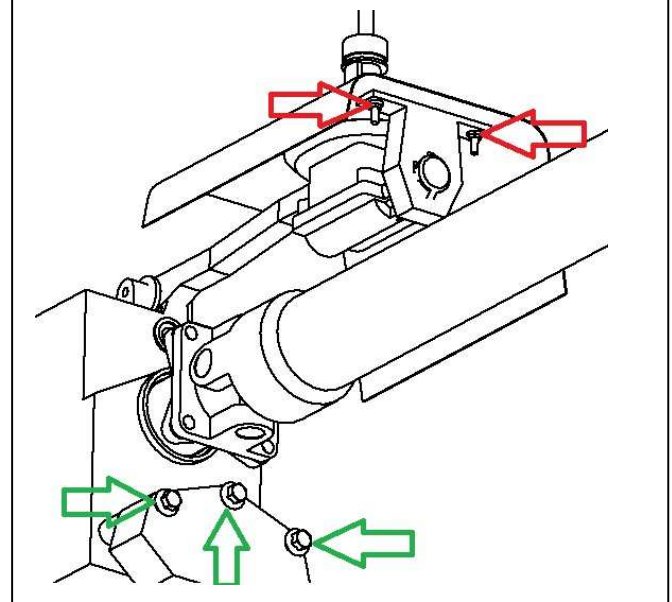
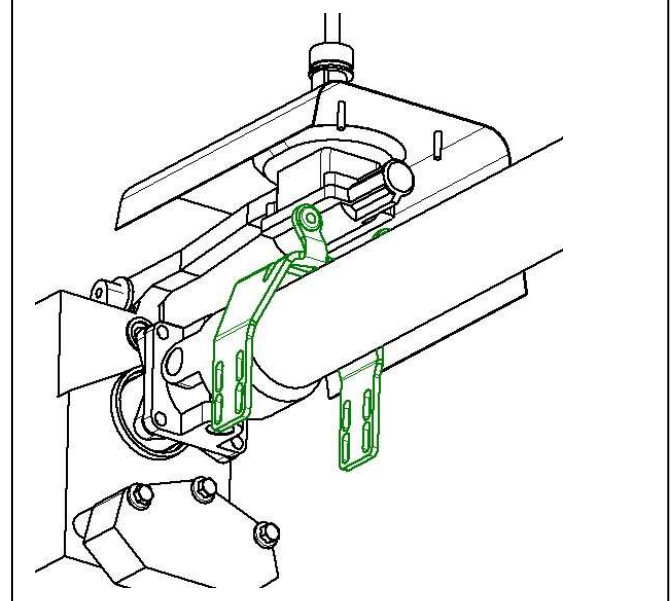

FIG 2-Upper Bracket Placement



STEP 5: Lower Bracket installation

Locate the (3) Bolts that attach the Transmission Mount Isolator to the Transmission (FIG 1, GREEN ARROWS). Using the 15mm Socket and Ratchet, loosen, BUT DO NOT REMOVE, the bolts to allow a bit more than a 1/4" gap between the Isolator Body and the backside of the bolt head. Bring the Lower Bracket up to the bolts and using the center "keyhole" (FIG 2, BLUE ARROW) as a reference point, place the Bracket over the center bolt head until it contacts the Isolator Body. Then, simply slide it downward to engage the Bracket's slots with the (3) bolts. If it will not engage, loosen the bolts a bit more and try again. Once the Bracket is completely seated, tighten the (3) bolts back up and torque to 35ft/lbs.

STEP 6: Snout Clamp Installation

Apply a small amount of Lubricant (anything non-solvent based) to the Lower Clamp Half Pins to aid in inserting Pins into Isolator Bushings. Slide the Pins into the backside of the Upper Bracket as shown in FIG 5. Using the supplied (2) M6 Hex Screws, attach the Isolation Clamp Assembly to the Shifter Box Snout. Position the Clamp as far rearward as possible. Torque bolts to 6ft/lbs.

STEP 7: Upper Bracket Attachment

With the Upper Bracket engaged with the Clamp Pins and the Lower Bracket nested between the flanges, position the Upper Bracket so the Slots line up with the rectangular holes in the Lower Bracket (as shown in FIG 6). If the slots are offset one set of holes back (which is normal for V6 and Ecoboost models), use the supplied Extension Bracket to effectively add an extra set of rectangular holes to the back of the Lower Bracket (as shown in FIG 5). Loosely attach the Upper and Lower Brackets (and Extension Bracket, if required) together using the supplied M10 Carriage Screws oriented with the heads on the surfaces closest to the driveshaft and Serrated Flange Hex Nuts on the outside surfaces. Adjust Upper Bracket Assembly upward until the shifter just touches the body. Do not force it to compress the rubber seal. If there is no upward adjustment left, leave the Bracket at the lowest position. Be sure the Upper Bracket is not contacting the bottom of the shifter box.

If it is, twist the Upper Bracket to bring the rear up and the front down. Tighten the Nuts to 35ftlbs.

STEP 8: Lower the Vehicle

Reverse the procedure you used in STEP 2.

STEP 9: ENJOY YOUR BLOWFISH RACING, LLC MT82 SHIFTER SUPPORT KIT!

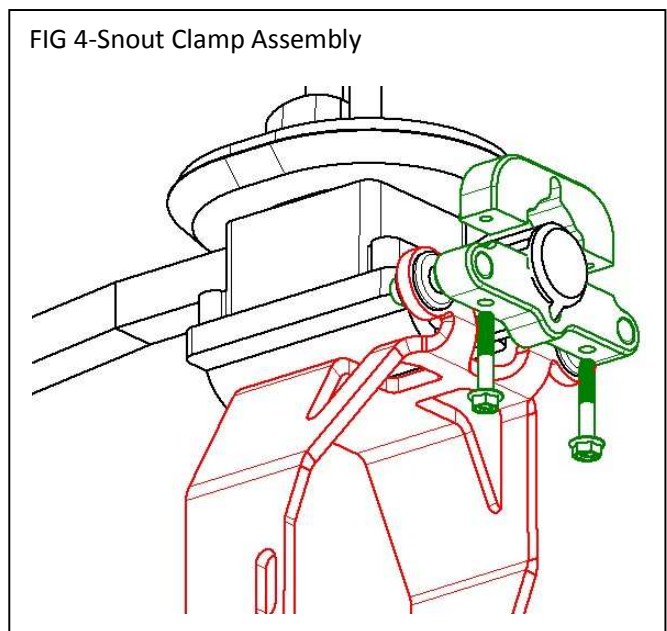
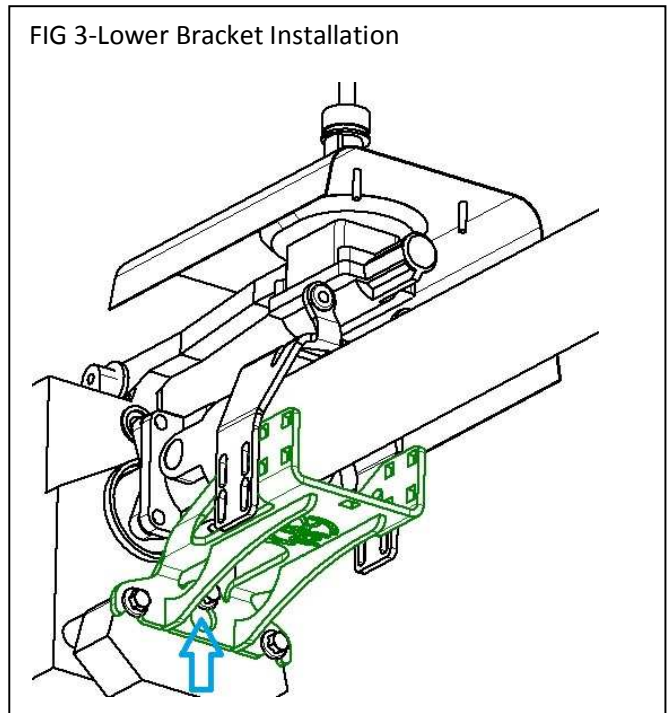

FIG 5-Final Assembly with Extension Bracket (V6 & Ecoboost)

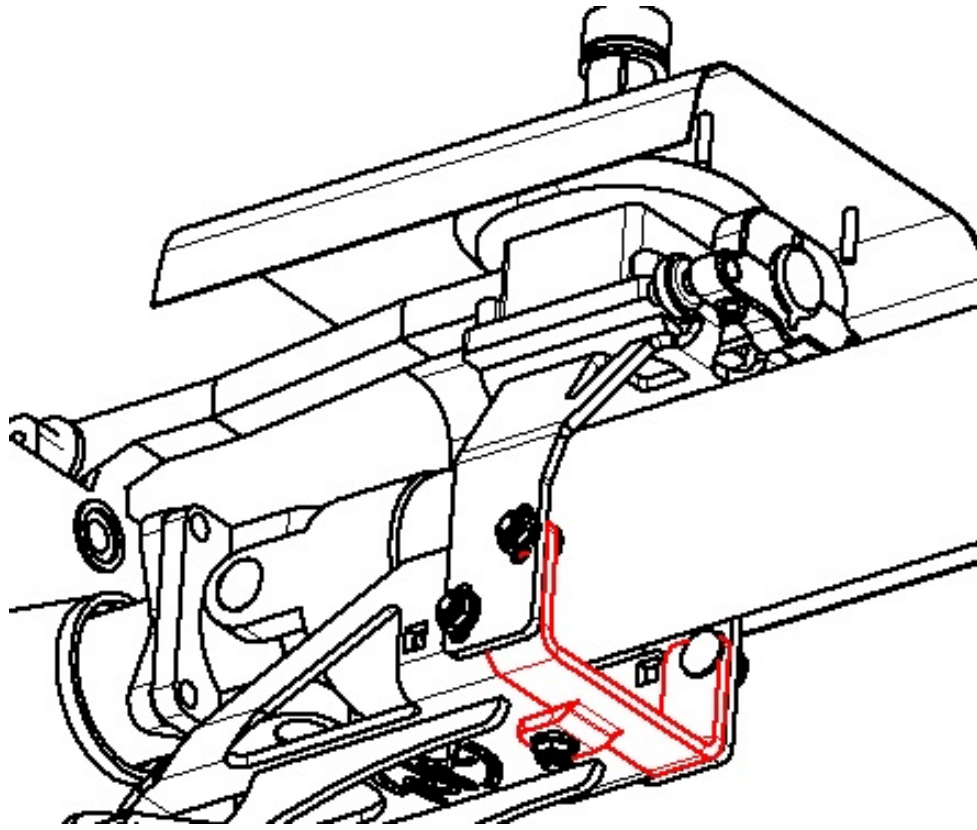

FIG 6-Final Assembly without Extension Bracket (V8)

